

EN

PVT 200-280-400-700-1000

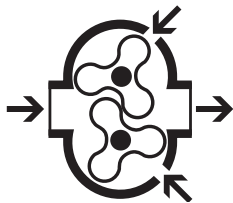

ORIGINAL INSTRUCTIONS

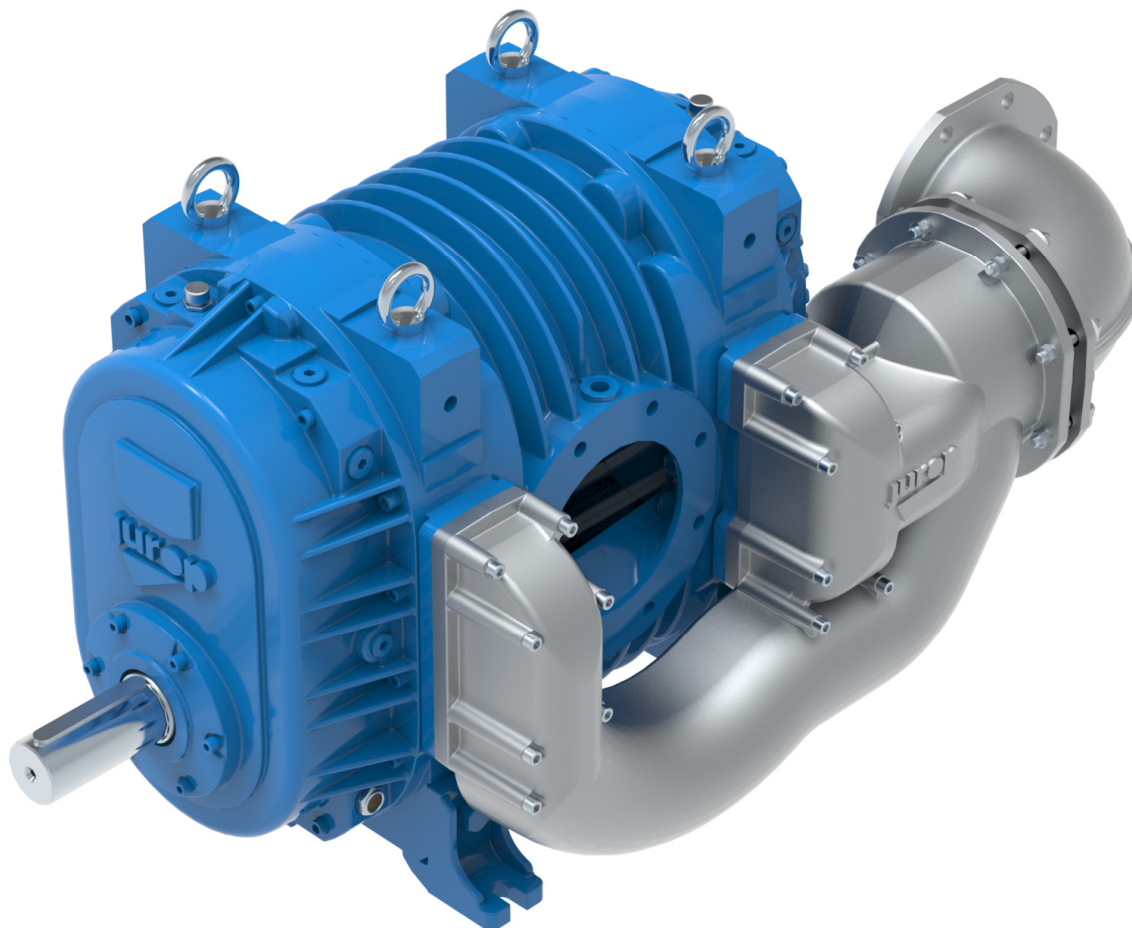

INSTALLATION, USE AND  
MAINTENANCE MANUAL

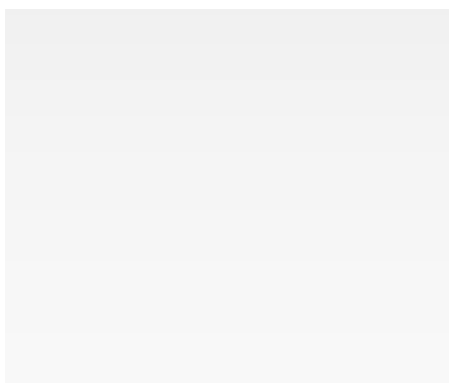

COMPANY WITH  
QUALITY SYSTEM  
CERTIFIED BY DNV GL  
= ISO 9001 =

Rev. 13  
03-08-2018

2018 – **Juop** – Azzano Decimo (PN)

Reproduction, electronic storage and dissemination, even partial, are prohibited.

Juop reserves the right to modify the products described in this manual without prior notice.

Any product names mentioned herein are the trademarks of their respective owners.

## Contents

<b>1. General information</b>	pag.	4	<b>9. Accessories</b>	pag.	35
1.1 Introduction		4	9.1 Silencers: models and dimensions		35
1.2 Spare part request		4	9.2 Accessories PVT 200-280-400		35
1.3 Warranty terms and conditions		4	9.3 Accessories PVT 700		37
<b>2. Technical data</b>	pag.	5	SPARE PART DATA SHEET – PVT 200		40
2.1 Arrangements PVT		5	SCHEMA RICAMBI – PVT 200 MULTIPLIER		42
2.2 Dimensions PVT		6	SPARE PART DATA SHEET – PVT 280-400 HDR		43
2.3 Operation in vacuum mode		11	SPARE PART DATA SHEET – PVT 280-400		44
2.4 Operation in pressure mode		16	SPARE PART DATA SHEET – PVT 700-1000		46
2.5 Noise level		21	SPARE PART DATA SHEET – PVT 700-1000 HDR		48
2.6 Usage limitations		23	SPARE PART DATA SHEET – SUCTION GROUP PVT		49
2.7 Lubrication		23	SPARE PART DATA SHEET – FLUSHING KIT		50
<b>3. Safety and accident prevention</b>	pag.	24			
3.1 General recommendations		24			
3.2 Intended use		24			
3.3 Conveyed fluids		24			
<b>4. Installation</b>	pag.	24			
4.1 Compulsory accessory		24			
4.2 Checking upon receipt		24			
4.3 Storing in the warehouse		25			
4.4 Handling and installation		25			
4.5 Mounting		25			
4.6 Vacuum – pressure line		26			
4.7 Air injection cooling system		27			
4.8 Overheating alarm		27			
4.9 Oil level alarm (optional)		28			
4.10 Drive systems		28			
<b>5. Start up</b>	pag.	30			
5.1 Starting-up		30			
5.2 Operating suggestions		30			
<b>6. Maintenance</b>	pag.	31			
6.1 Ordinary maintenance		31			
6.2 Extraordinary maintenance		32			
<b>7. Malfunctions: troubleshooting</b>	pag.	34			
<b>8. Scrapping</b>	pag.	34			

## 1. General information

### 1.1 Introduction

• This booklet contains the necessary instructions for a correct installation, running, use and maintenance of the compressor, as well as some practical suggestions for a safe operating.

• The knowledge of the following pages will grant a long and trouble-free operation of the compressor.

• Following the instructions below contributes to limiting pump repair expenses by extending its duration, as well as preventing hazardous situations, thereby increasing its reliability.

• If the pump is driven by an hydraulic motor please refer to manufacturer's specific manual.

• It is recommended to:

- Understand and apply carefully the instructions before running the pump.
- Keep the booklet at hand and have it known to all operators.

• Below is a brief description of the symbols used in this manual.



If these safety rules are not respected, operators can be injured and the compressor or oilers damaged remarkably.



If these safety rules are not respected, the compressor or system can be damaged.



Suggestions for an environment friendly use of the compressor.



Useful information for an easy usage and maintenance of the compressor.

• The graphic representations and photographs contained in this manual are there to illustrate the product in the parts that make it up and in specific operating phases. Though the model shown in the manual may differ from the one purchased, the operating principle at the base of the illustrated operating phase is the same.

• Each PVT shows a manufacturer plate that specifies:

1. PVT Model
2. Serial Number
3. Year of manufacture
4. Max Pressure
5. Maximum speed at maximum vacuum rate
6. Maximum speed at vacuum rate equal of 80%
7. Maximum required power

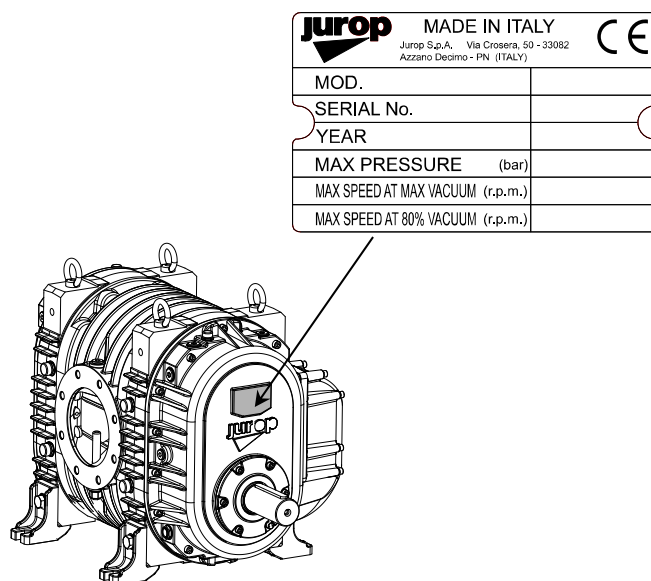

Pic. 1.1

### 1.2 Spare part request

• Use only **genuine spare parts** for maintenance and repairs. To order spare parts, provide the following details:

EXAMPLE:

- |   |              |
|---|--------------|
| a) The model of the compressor (see compressor tag)         | PVT400       |
| b) The serial number of the compressor (see compressor tag) | K80001       |
| c) A description of the parts (see parts list)              | GASKET       |
| d) The quantity (see parts list)                            | n°1 pz       |
| e) The code number of the part (see parts list)             | 16807 084 00 |

### 1.3 Warranty terms and conditions

• Compliance with the installation, use and maintenance instructions provided by this manual **is crucial for the recognition of warranty** against defective parts.

## 2. Technical data

• PVT vacuum pumps are 3 lobe blowers specifically designed for vacuum plants that must convey gas free from polluting substances, oil or water: this is made possible due to the lack of sliding parts, and therefore oil lubrication within the compression chambers. Moreover, PVT blowers do not need any auxiliary cooling system, as they are provided with a built in air injection cooling system. The specific and accurate lobes profiles grant high volumetric efficiency and high flow rates combined with minimized dimensions and vacuum rates that can reach 93%.

- Tri-lobe rotary volumetric pump with synchronised phase helical gears.
- No oil emission into the atmosphere.
- Wear-proof operation, reduced maintenance.
- Clockwise or counter clockwise rotation on request.
- Dynamically balanced rotors to reduce vibrations (A).
- Splash lubricated bearings (B) and gears (C) in the front and rear boxes.
- Internal combined seals: Y-seals and labyrinth seals (D) with PTFE/cast iron rings with discharge into the atmosphere.
- Seals and gaskets for high temperatures.
- Side Air injection cooling system with clapet valve (E). This valve opens only in the vacuum functioning mode.
- Injection silencer (compulsory accessory) and vacuum pump exhaust.
- Overheating thermostat on the exhaust port (F).
- Removable lifting points (G)(H).

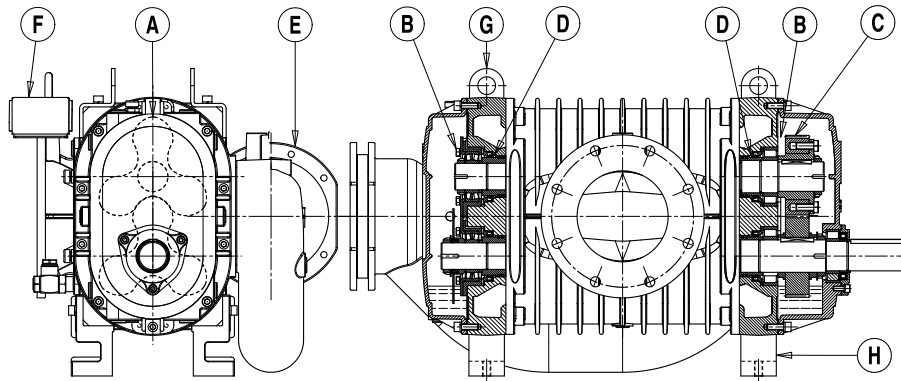

### 2.1 Arrangements PVT

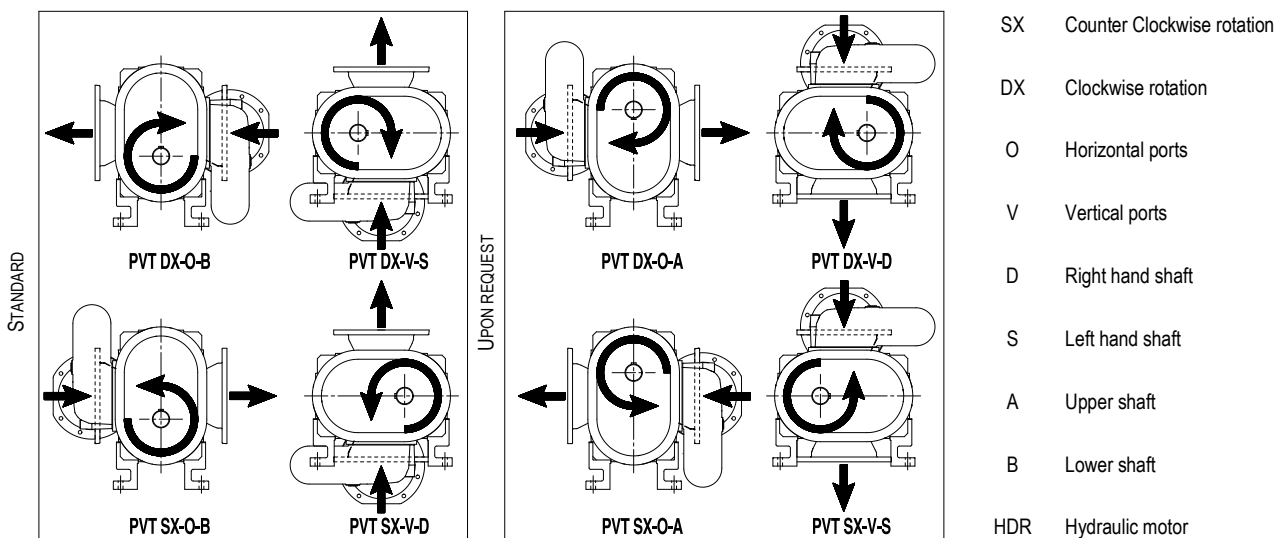

**Note:** PVT 200M (with gearbox 3:1) is available only in the following arrangements PVT DX-O-B e PVT SX-O-B.

## 2.2 PVT Dimensions

### Direct Transmission - HDR

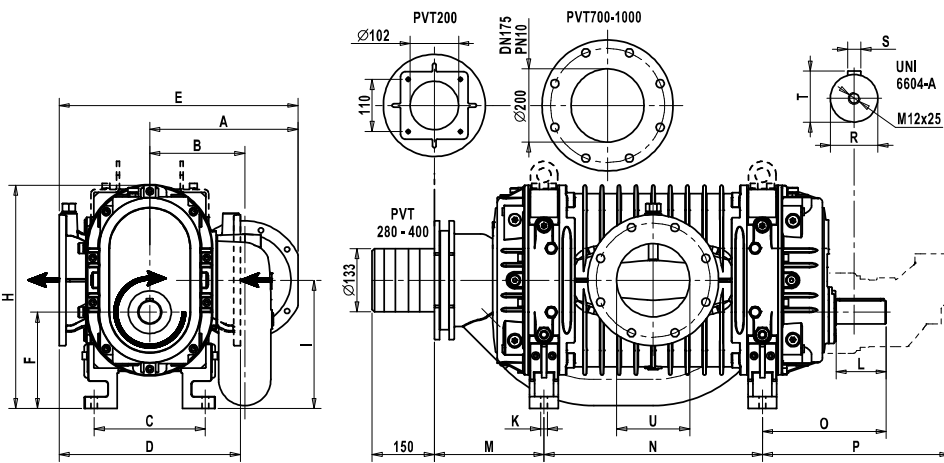

Code	Description
G170851102	PVT200 DX-O-B
G540851102	PVT280 DX-O-B
G230851102	PVT400 DX-O-B
G160851102	PVT700 DX-O-B
G270851102	PVT1000 DX-O-B
F178151102	PVT200 DX-O-B-HDR
F828151102	PVT280 DX-O-B-HDR
F838151102	PVT400 DX-O-B-HDR
F508151102	PVT700 DX-O-B-HDR
F278151102	PVT1000 DX-O-B-HDR

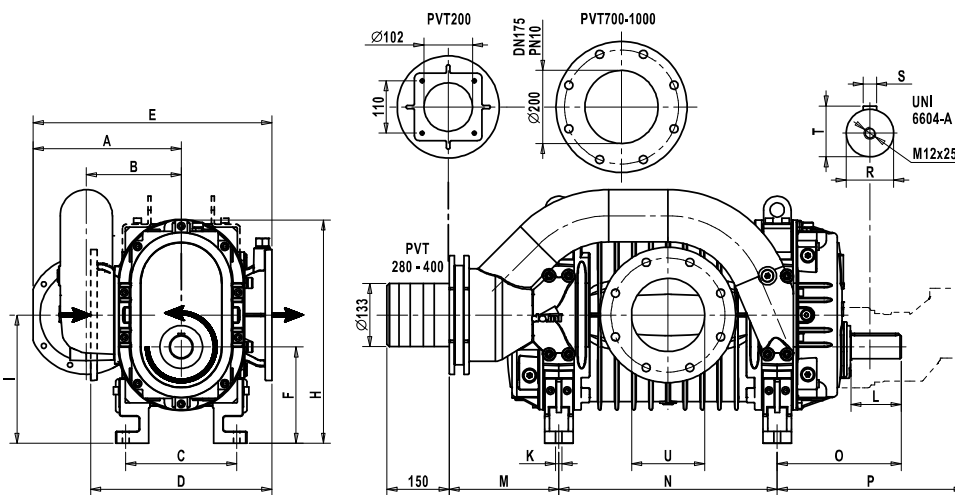

Code	Description
G170951102	PVT200 SX-O-B
G540951102	PVT280 SX-O-B
G230951102	PVT400 SX-O-B
G160951102	PVT700 SX-O-B
G270951102	PVT1000 SX-O-B
F170951102	PVT200 SX-O-B-HDR
F828051102	PVT280 SX-O-B-HDR
F838051102	PVT400 SX-O-B-HDR
F508051102	PVT700 SX-O-B-HDR
F278051102	PVT1000 SX-O-B-HDR

	A	B	C	D	E	F	H	I	K	L	M
PVT 200	276	168	176	270	458	155	373	207	M 14	69	266
PVT 280	312	200	200	312	468	167	436	234	M 14	86	231
PVT 400	312	200	236	392	508	203	470	270	M 14	106	231
PVT 700	386	239	532	438	623	234	658	339	M 20	150	344
PVT 1000	386	239	532	462	623	234	658	339	M 20	150	344

	N	O	P	R	S	T	U	Weight
PVT 200	328	154	428	38 g6 -0.009 -0.025	10	41	110 DN100 PN6 UNI2276-67	160 Kg
PVT 280	350	241	379 *	50 g6 -0.009 -0.025	14	53.5	122 DN100 PN10 UNI2277-67	192 Kg
PVT 400	460	261	395 *	50 g6 -0.009 -0.025	14	53.5	155 DN150 PN10 UNI2277-67	240 Kg
PVT 700	422	385	512 *	70 g6 -0.010 -0.029	20	74.5	200 DN175 PN10 UNI2277-67	640 Kg
PVT 1000	630	385	828	70 g6 -0.010 -0.029	20	74.5	220 DN200 PN10 UNI2277-67	780 Kg

\* Hydraulic transmission: compact model.

**Code Description**

- G170951101 PVT200 SX-O-A
- G540951101 PVT280 SX-O-A
- G230951101 PVT400 SX-O-A
- G160951101 PVT700 SX-O-A
- G270951101 PVT1000 SX-O-A

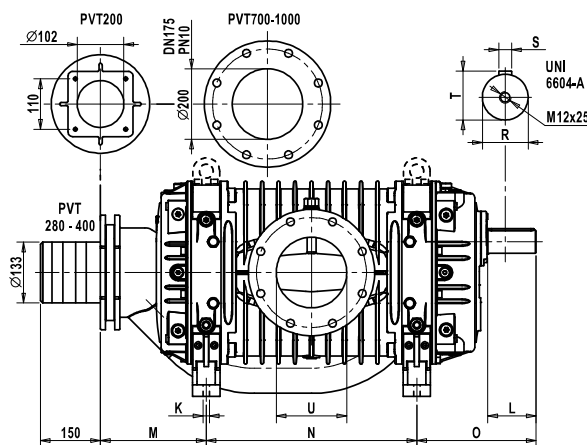
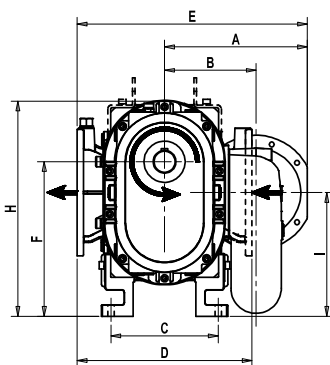

**Code Description**

- G170851101 PVT200 DX-O-A
- G540851101 PVT280 DX-O-A
- G230851101 PVT400 DX-O-A
- G160851101 PVT700 DX-O-A
- G270851101 PVT1000 DX-O-A

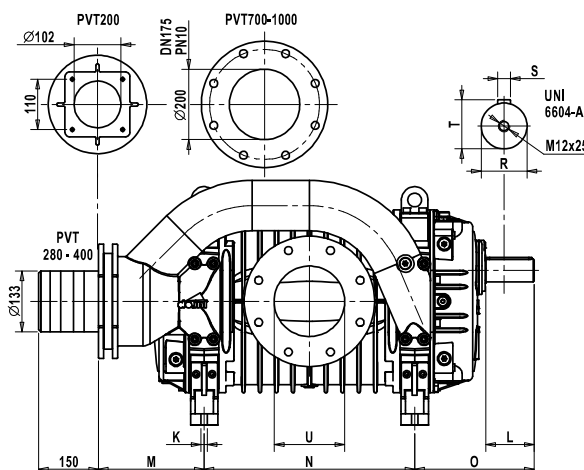
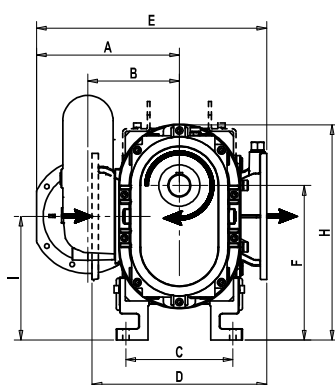

	A	B	C	D	E	F	H	I	K	L
PVT 200	276	168	176	270	458	259	373	207	M 14	69
PVT 280	312	200	200	312	468	301	436	234	M 14	86
PVT 400	312	200	236	392	508	337	470	270	M 14	106
PVT 700	386	239	532	438	623	444	658	339	M 20	150
PVT 1000	386	239	532	462	623	444	658	339	M 20	150

	M	N	O	R	S	T	U	Weight
PVT 200	266	328	154	38 g6 -0.009 -0.025	10	41	110 DN100 PN6 UNI2276-67	160 Kg
PVT 280	231	350	241	50 g6 -0.009 -0.025	14	53.5	122 DN100 PN10 UNI2277-67	192 Kg
PVT 400	231	460	261	50 g6 -0.009 -0.025	14	53.5	155 DN150 PN10 UNI2277-67	240 Kg
PVT 700	344	422	385	70 g6 -0.010 -0.029	20	74.5	200 DN175 PN10 UNI2277-67	640 Kg
PVT 1000	344	630	385	70 g6 -0.010 -0.029	20	74.5	220 DN200 PN10 UNI2277-67	780 Kg

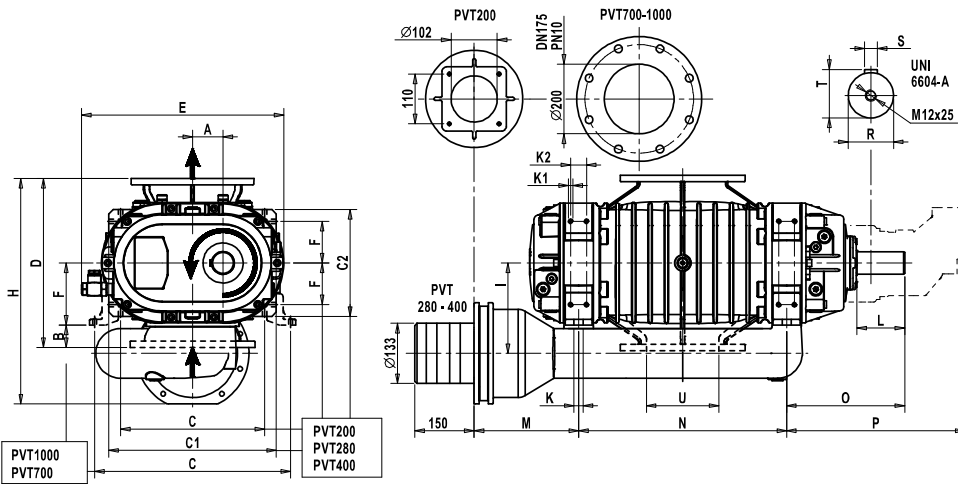

Code	Description
G170850103	PVT200 DX-V-S
G540850103	PVT280 DX-V-S
G230850103	PVT400 DX-V-S
G160850103	PVT700 DX-V-S
G270850103	PVT1000 DX-V-S
F178150103	PVT200 DX-V-S-HDR
F828150103	PVT280 DX-V-S-HDR
F838150103	PVT400 DX-V-S-HDR
F508150103	PVT700 DX-V-S-HDR
F278150103	PVT1000 DX-V-S-HDR

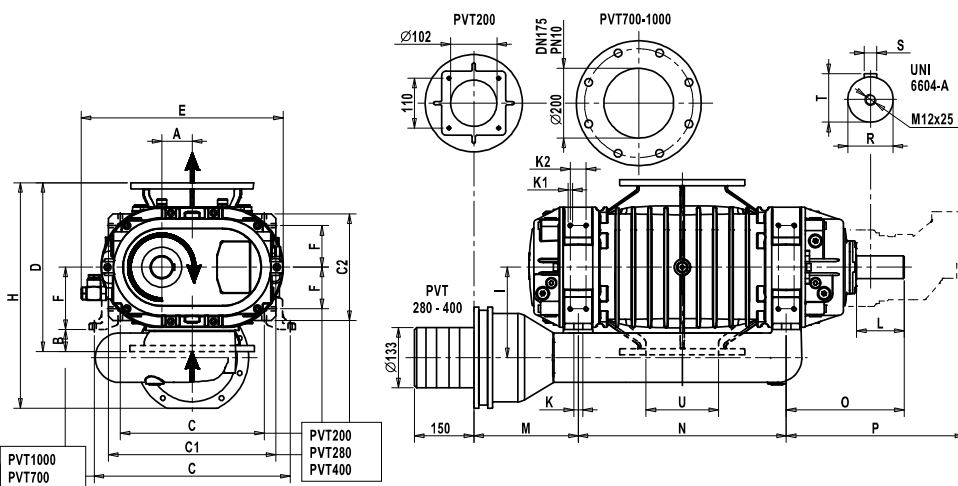

Code	Description
G170950104	PVT200 SX-V-D
G540950104	PVT280 SX-V-D
G230950104	PVT400 SX-V-D
G160950104	PVT700 SX-V-D
G270950104	PVT1000 SX-O-D
F178050104	PVT200 SX-V-D-HDR
F828050104	PVT280 SX-V-D-HDR
F838050104	PVT400 SX-V-D-HDR
F508050104	PVT700 SX-V-D-HDR
F278050104	PVT1000 SX-V-D-HDR

	A	B	C	C1	C2	D	E	F	H	I	K	K1	K2
PVT 200	52	-	264	316	212	270	381	80	430	168	-	M10	35
PVT 280	67	-	318.6	372	236	312	413	92	468	200	-	M10	35
PVT 400	67	-	318.6	372	236	392	448	92	508	200	-	M10	35
PVT 700	105	-15	745	-	-	438	642	234	339	623	M20	-	-
PVT 1000	105	-15	745	-	-	462	642	234	339	623	M20	-	-

	L	M	N	O	P	R	S	T	U	Weight	
PVT 200	69	266	328	154	428	38 g6 -0.009 -0.025	10	41	110	DN100 PN6 UNI2276-67	160 Kg
PVT 280	86	231	350	241	379 *	50 g6 -0.009 -0.025	14	53.5	122	DN100 PN10 UNI2277-67	192 Kg
PVT 400	106	231	460	261	395 *	50 g6 -0.009 -0.025	14	53.5	155	DN150 PN10 UNI2277-67	240 Kg
PVT 700	150	344	422	385	512 *	70 g6 -0.010 -0.029	20	74.5	200	DN175 PN10 UNI2277-67	640 Kg
PVT 1000	150	344	630	385	828	70 g6 -0.010 -0.029	20	74.5	220	DN200 PN10 UNI2277-67	780 Kg

\* Hydraulic transmission: compact model.



**Code Description**

- G170950103 PVT200 SX-V-S
- G540950103 PVT280 SX-V-S
- G230950103 PVT400 SX-V-S
- G160950103 PVT700 SX-V-S
- G270950103 PVT1000 SX-V-S

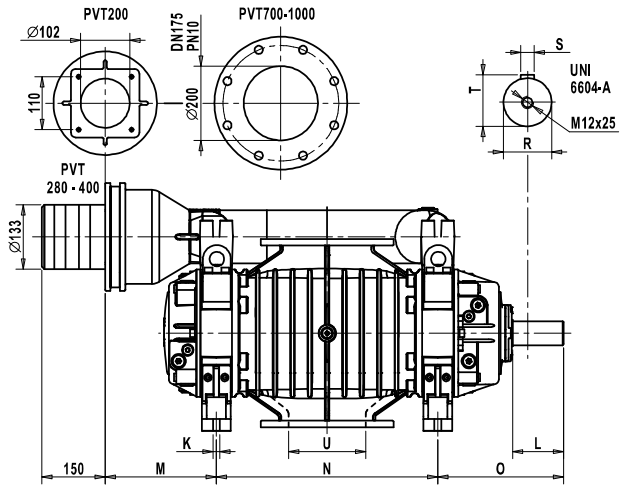
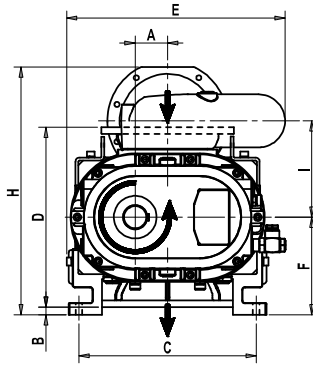

**Code Description**

- G170850104 PVT200 DX-V-D
- G540850104 PVT280 DX-V-D
- G230850104 PVT400 DX-V-D
- G160850104 PVT700 DX-V-D
- G270850104 PVT1000 DX-V-D

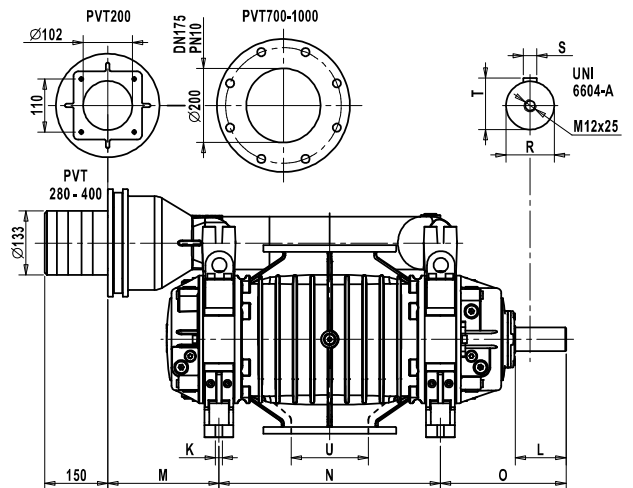
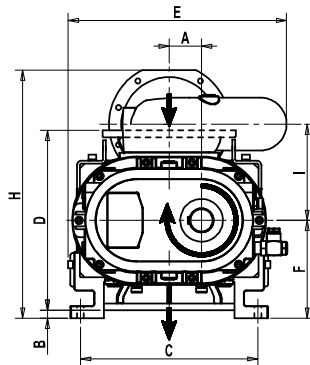

	A	B	C	D	E	F	H	I	K	L
PVT 200	52	20	280	270	381	155	432	168	M14	69
PVT 280	67	11	335	312	413	167	479	200	M14	86
PVT 400	67	7	372	392	448	203	515	200	M14	106
PVT 700	105	15	745	438	641	234	432	239	M20	150
PVT 1000	105	15	745	462	641	234	432	239	M20	150

	M	N	O	R	S	T	U	Weight
PVT 200	266	328	154	38 g6 -0.009 -0.025	10	41	110 DN100 PN6 UNI2276-67	160 Kg
PVT 280	231	350	241	50 g6 -0.009 -0.025	14	53.5	122 DN100 PN10 UNI2277-67	192 Kg
PVT 400	231	460	261	50 g6 -0.009 -0.025	14	53.5	155 DN150 PN10 UNI2277-67	240 Kg
PVT 700	344	422	385	70 g6 -0.010 -0.029	20	74.5	200 DN175 PN10 UNI2277-67	640 Kg
PVT 1000	344	630	385	70 g6 -0.010 -0.029	20	74.5	220 DN200 PN10 UNI2277-67	780 Kg

Transmission with multiplier

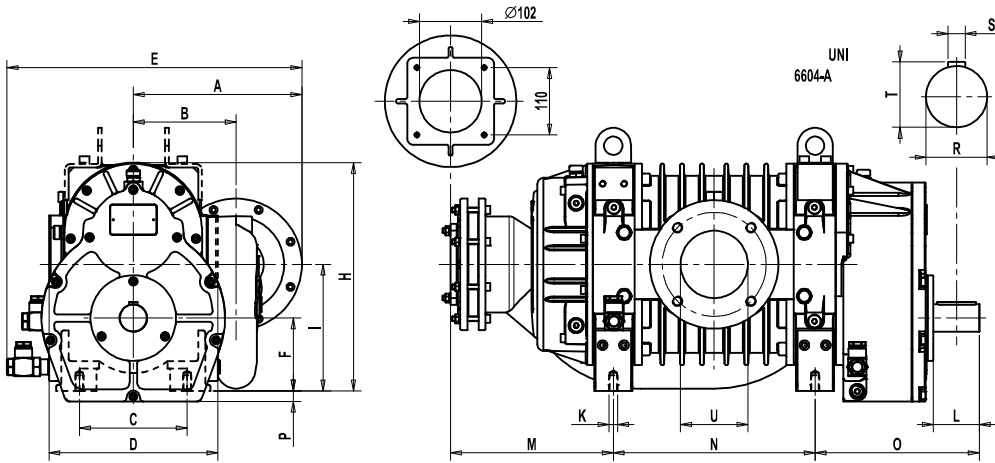

Code	Description
G177751100	PVT200 DX-O MULTIPLIER

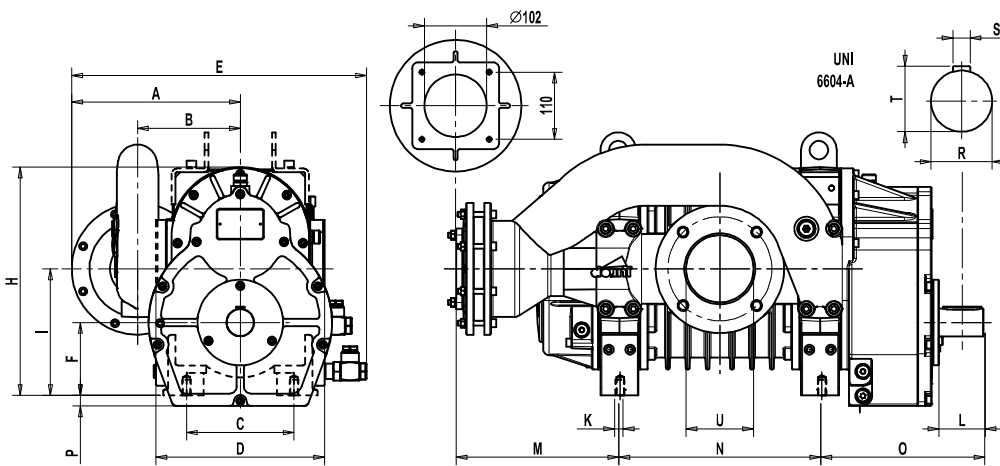

Code	Description
G177851100	PVT200 SX-O MULTIPLIER

	A	B	C	D	E	F	H	I	K	L	M
PVT 200M	276	168	176	270	482	119	373	207	M14	74	266

	N	O	P	R	S	T	U	Weight	
PVT 200M	328	269	17	45 g6	-0.009 -0.025	14	48.5	110 DN100 PN6 UNI2276-67	210 Kg

## 2.3 Performances – Operation in vacuum mode

### REFERENCE CONDITIONS

Absolute reference pressure: 1013 mbar abs  
Counter pressure at the exhaust port: 1013 mbar abs

Ambient reference temperature: 20°C  
Tolerances on the air flow and power: ±5%

- PVT200M performances are identical to PVT200 performances. The rotation speed of the PVT200M is 1/3 of the rotation speed showed on the graphs.
- Broken line speed: MAX vacuum rate 80%.

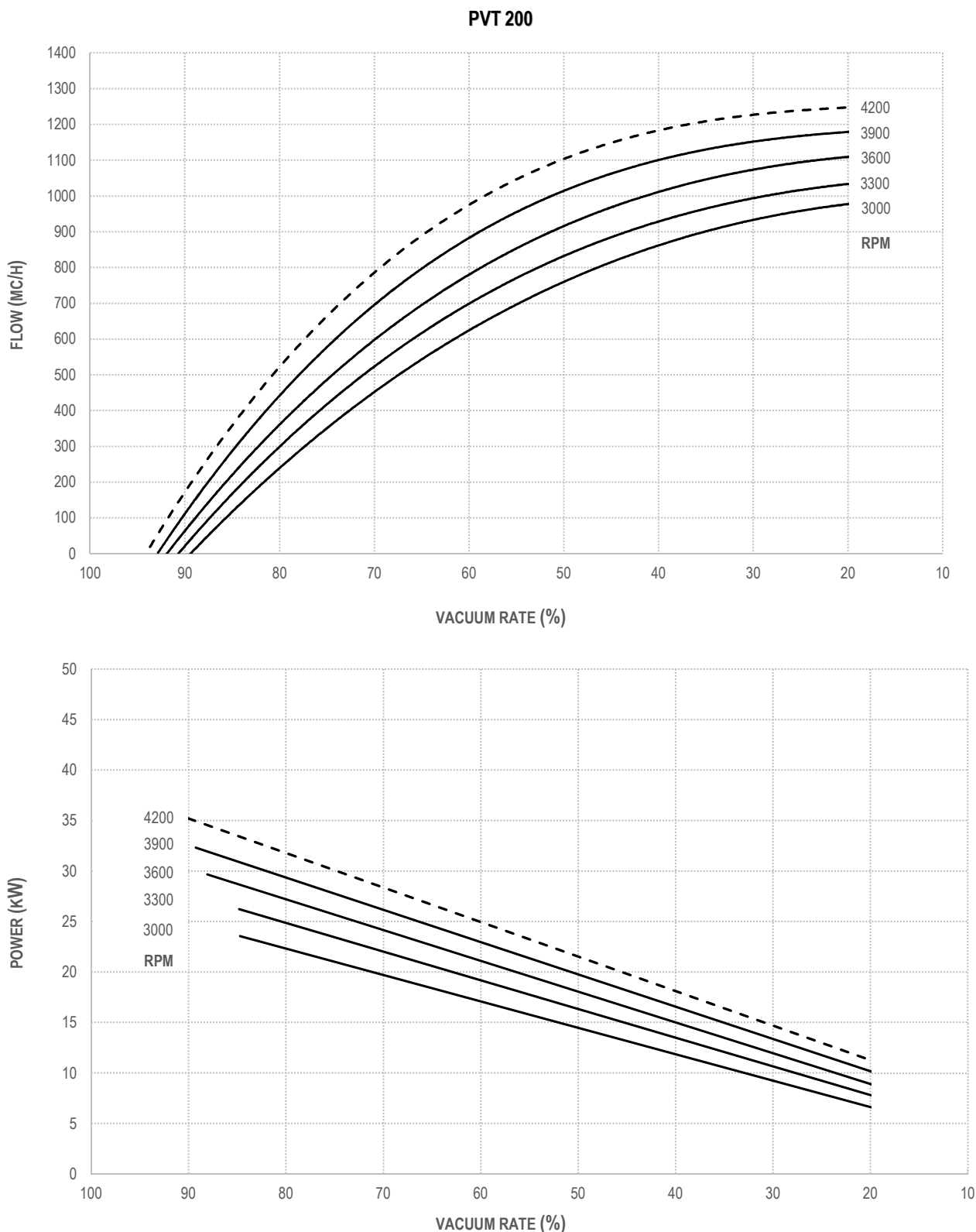

**PVT 280**

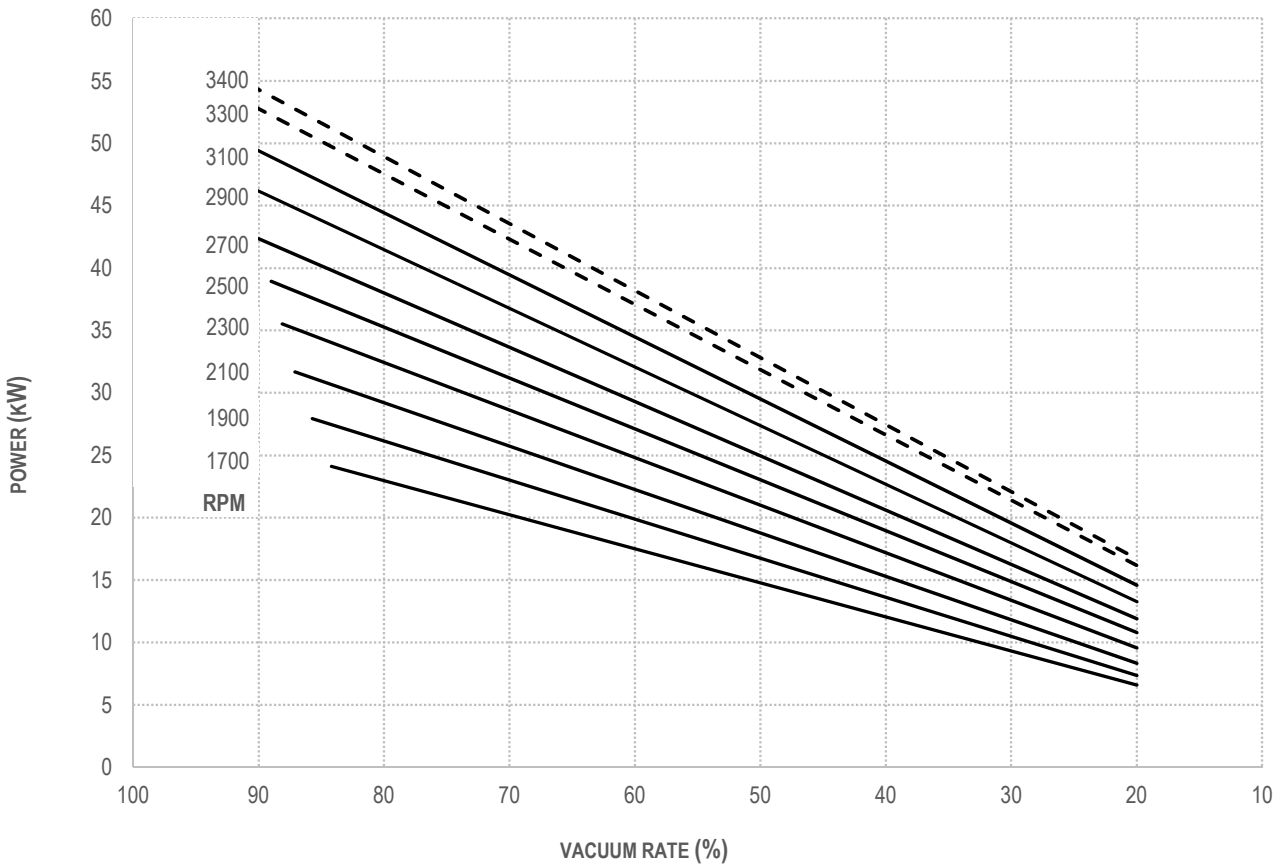
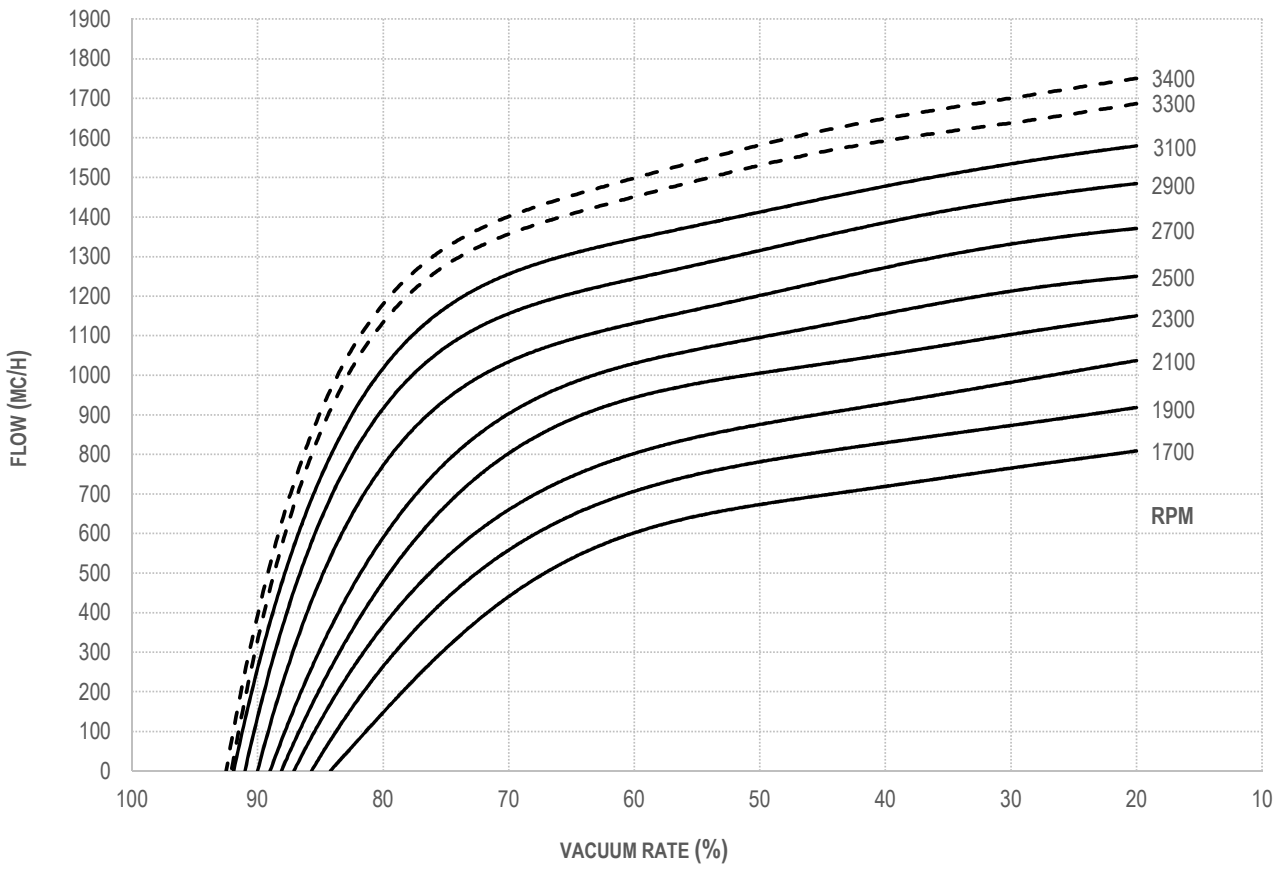

**PVT 400**

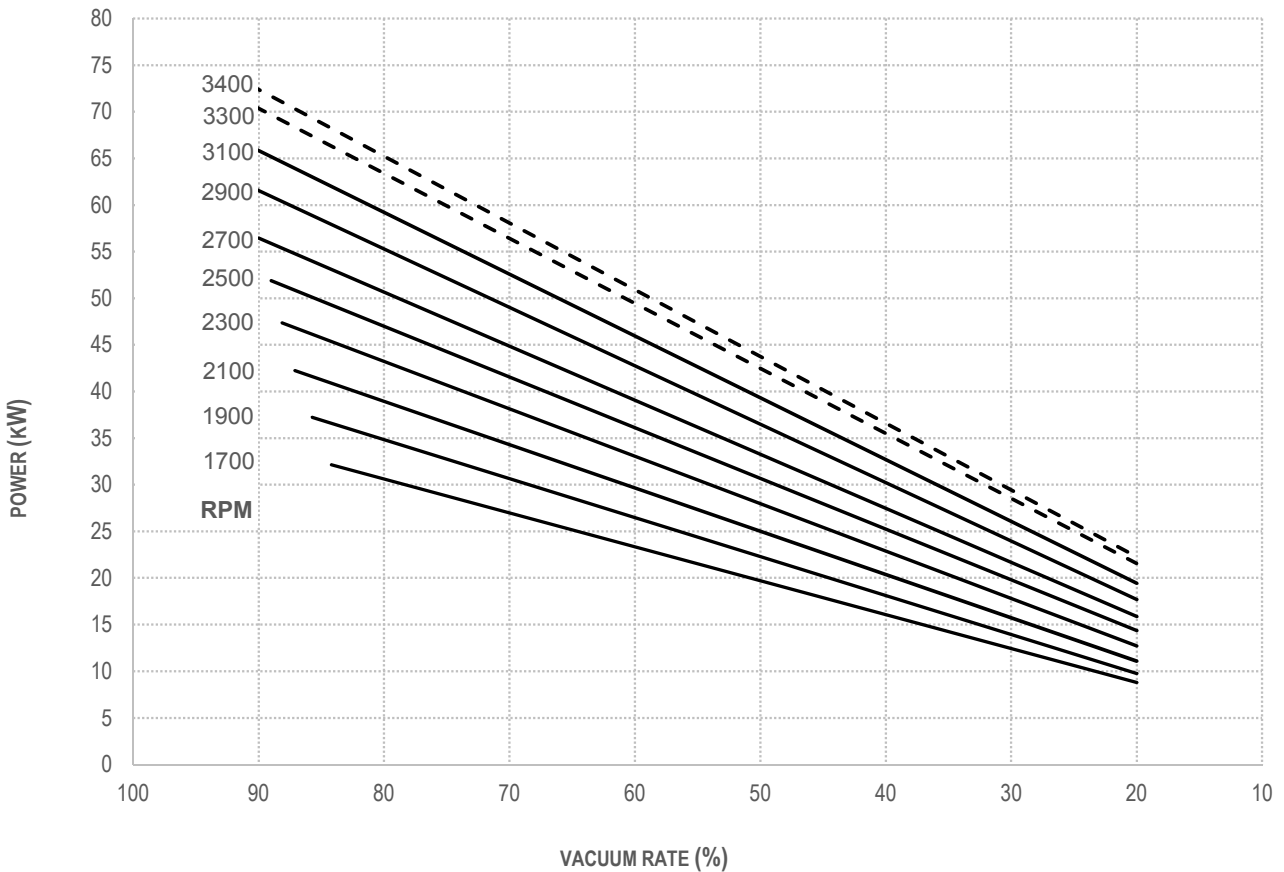
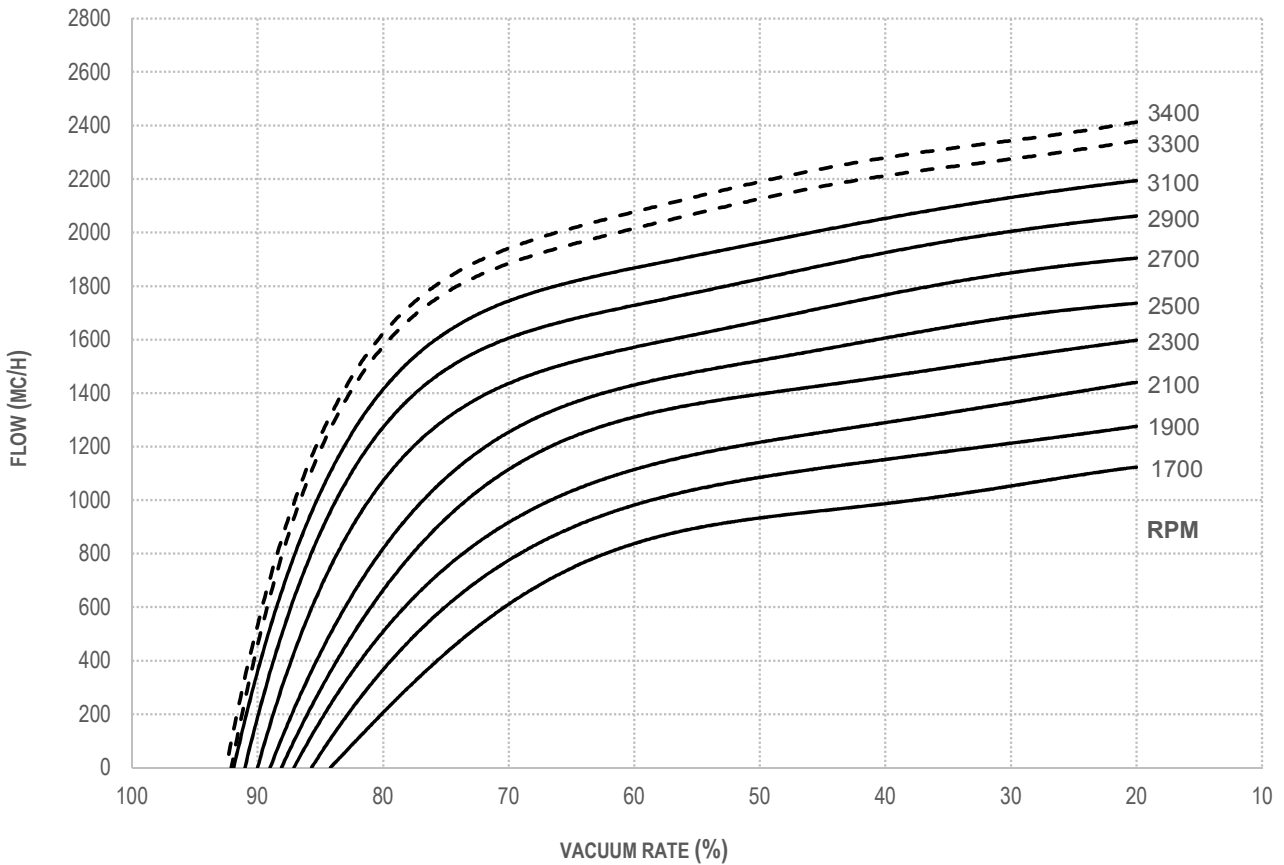

**PVT 700**

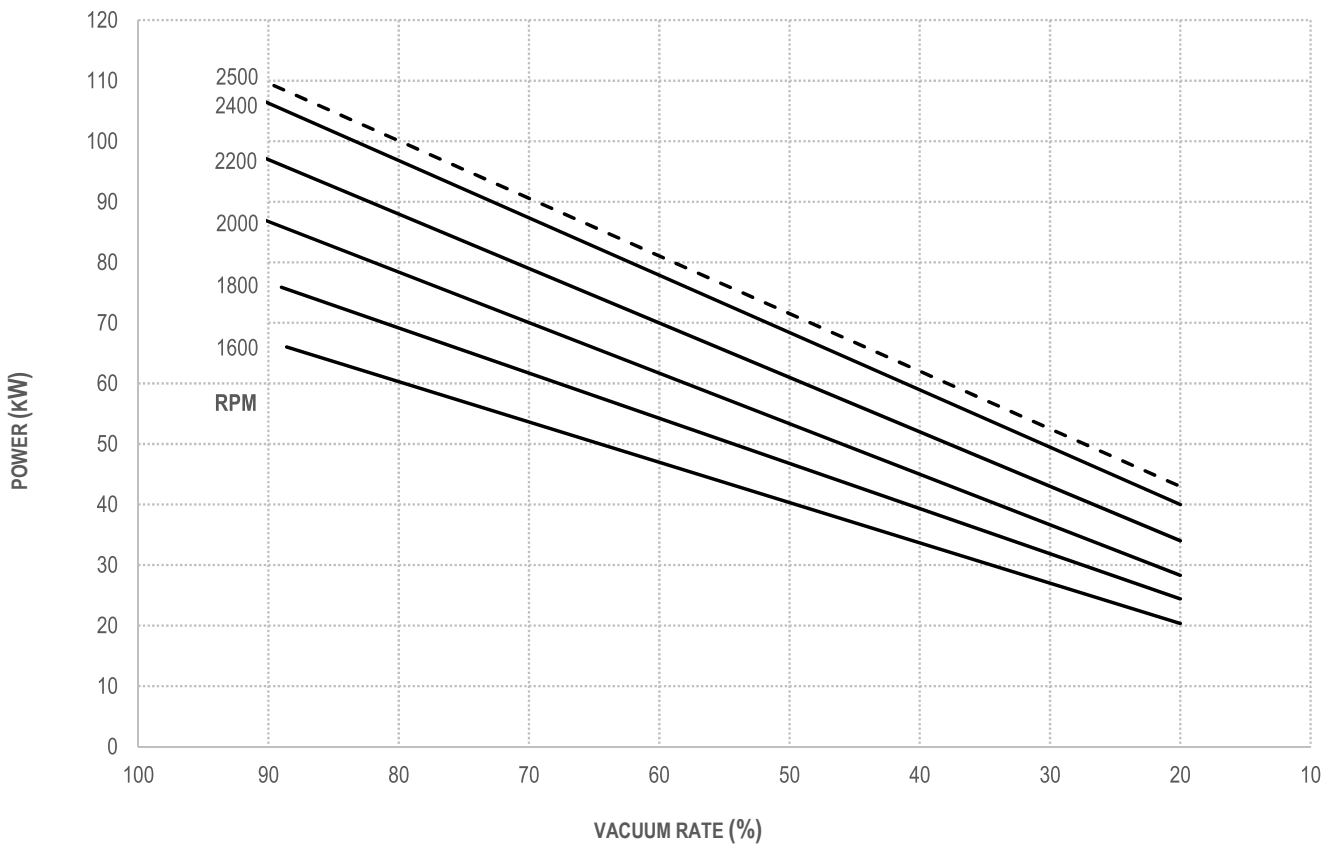
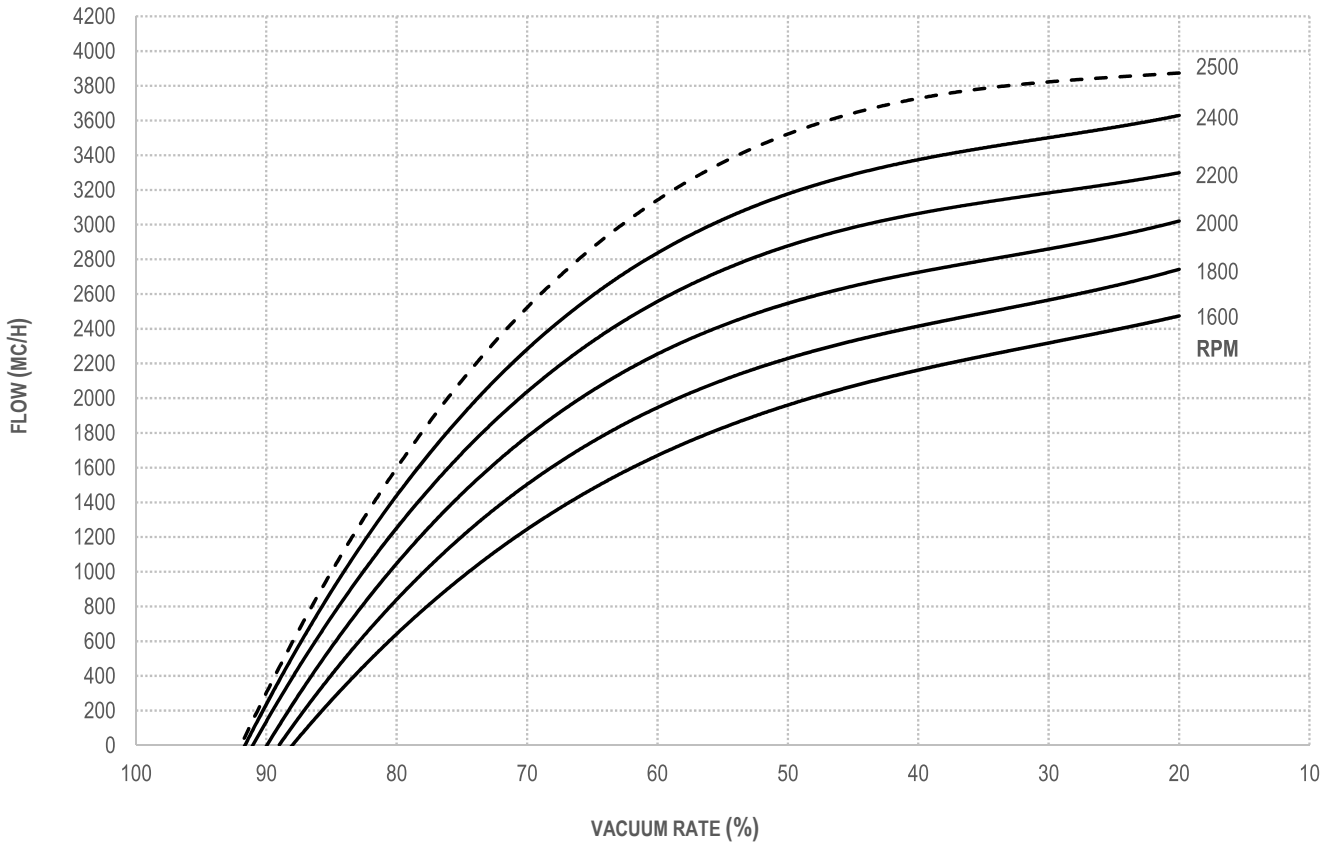

PVT1000

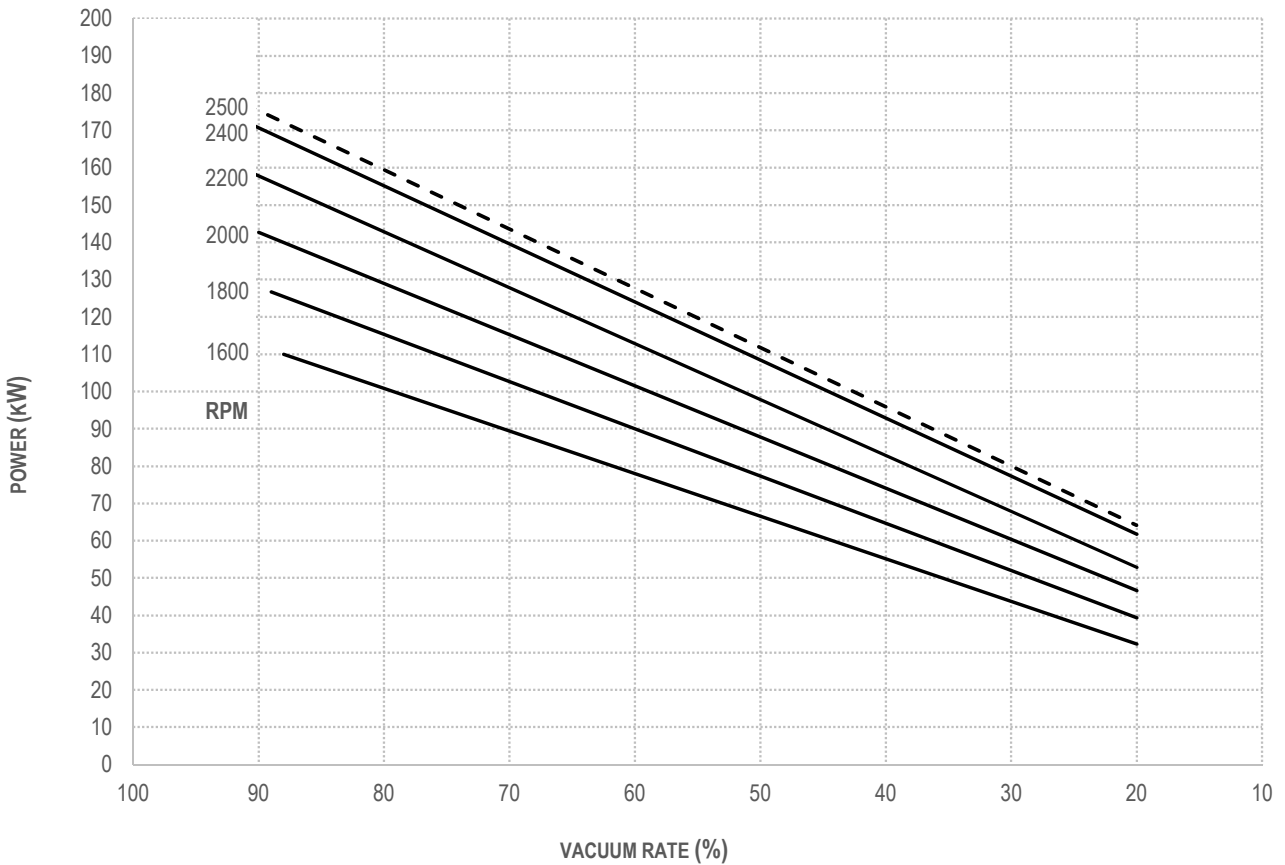
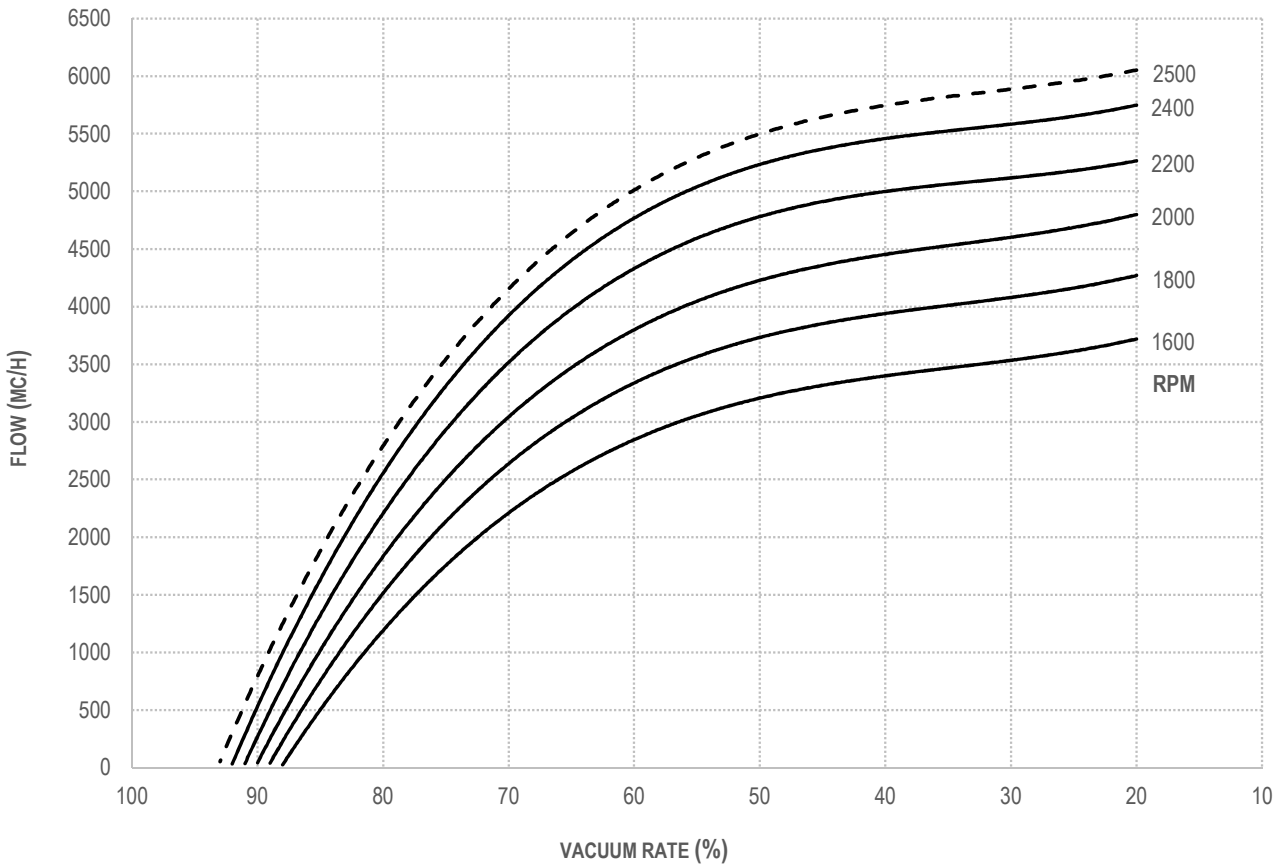

## 2.4 Performances – Operation in pressure mode

### REFERENCE CONDITIONS

Absolute reference pressure: 1013 mbar abs  
Suction temperature: 1013 mbar abs

Ambient temperature: 20°C  
Tolerances on the air flow and power: ±5%

- PVT operations with exhaust pressure higher than 800 – 1000 mbar rel are allowed only in intermittent duty.
- PVT200M performances are identical to PVT200 performances. The rotation speed of the PVT200M is 1/3 of the rotation speed showed on the graphs.

### PVT 200

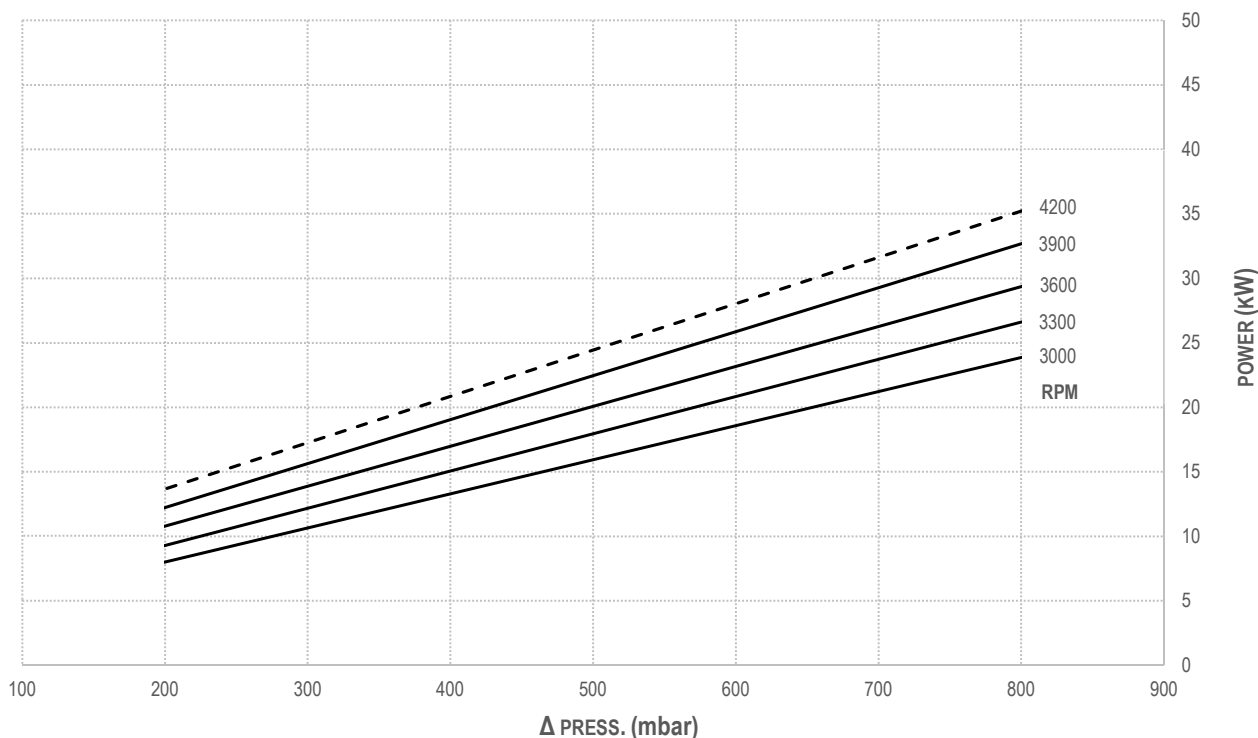
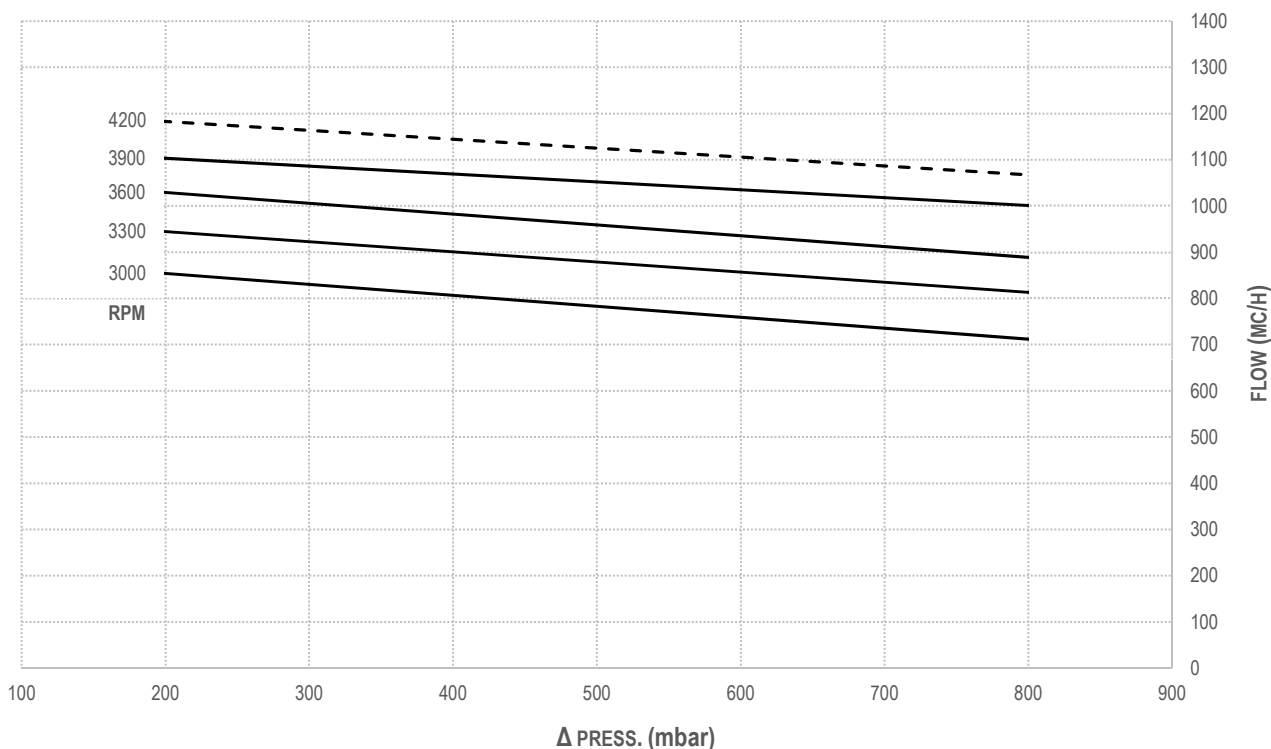



PVT 280

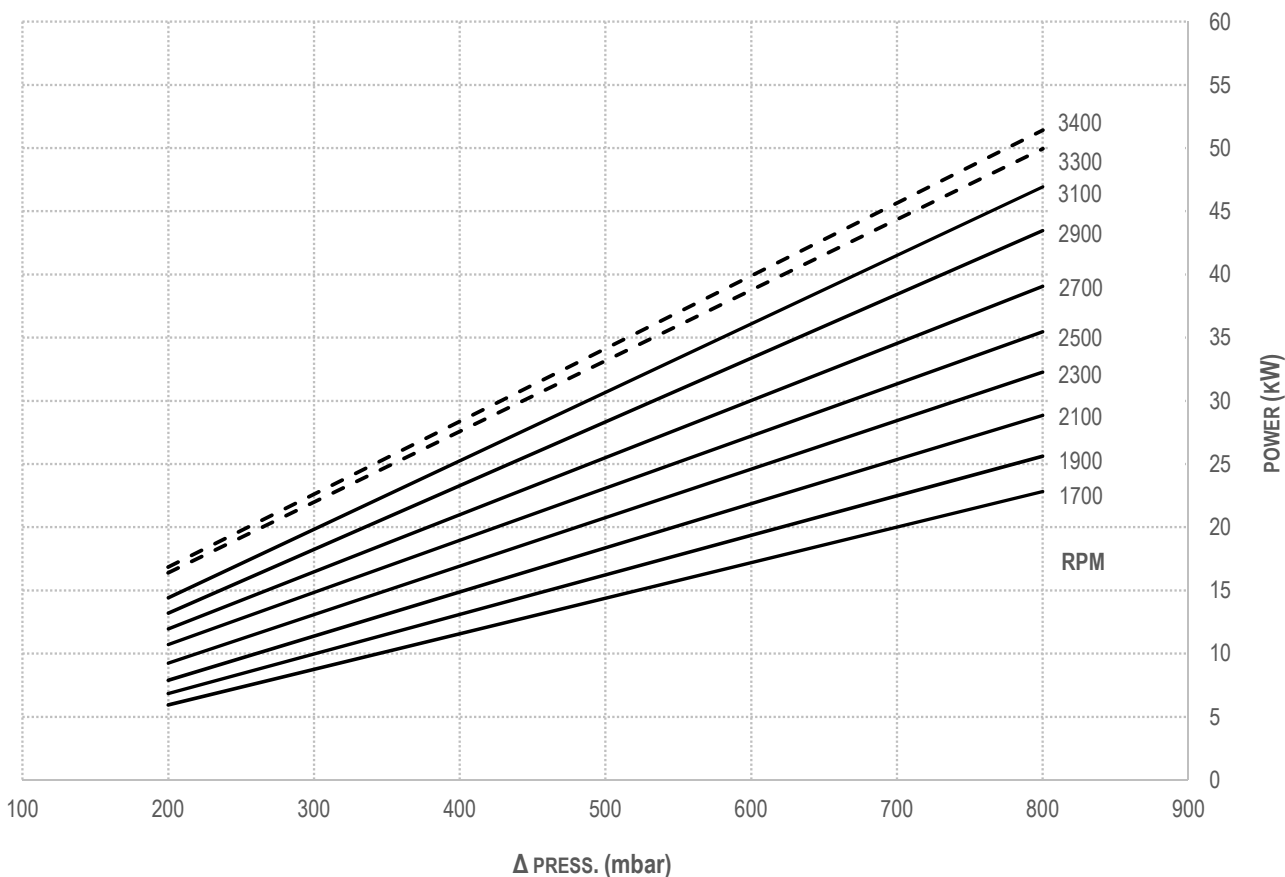
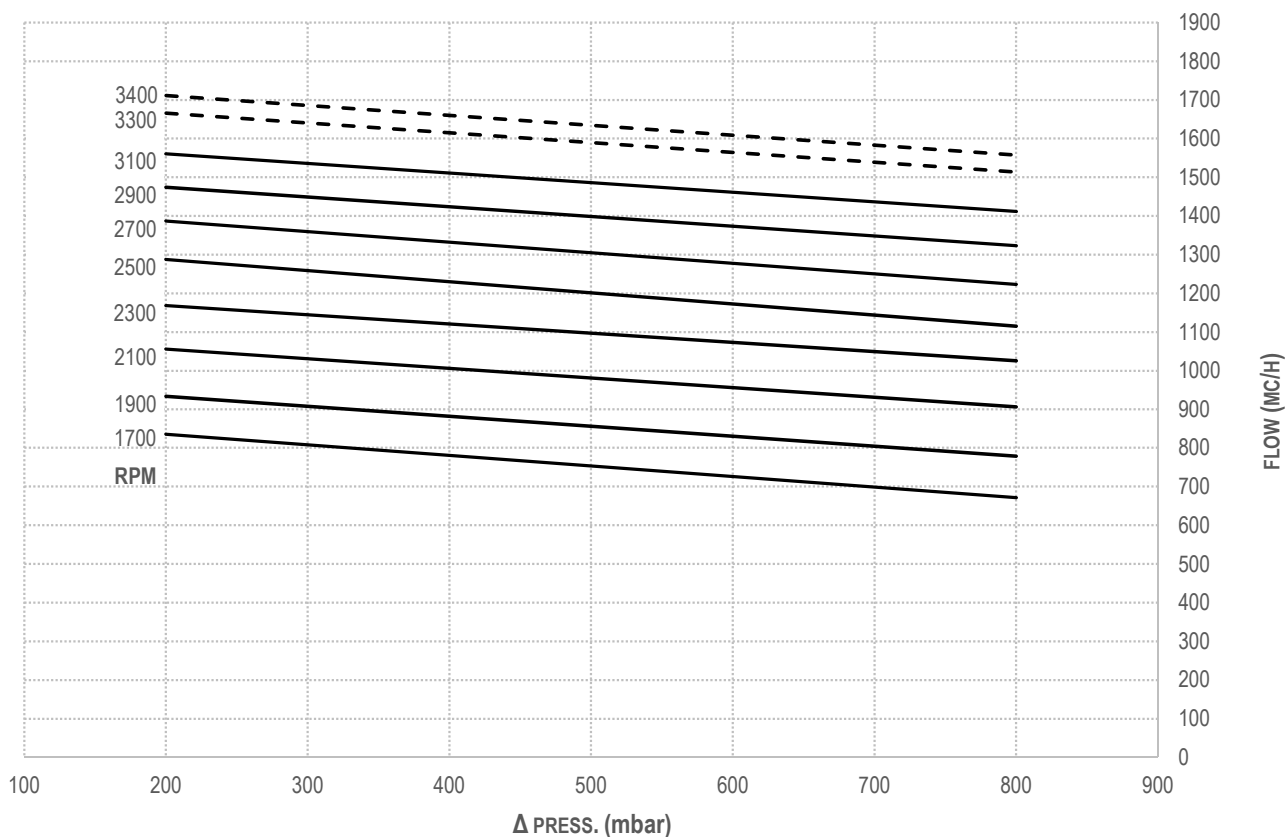

**PVT 400**

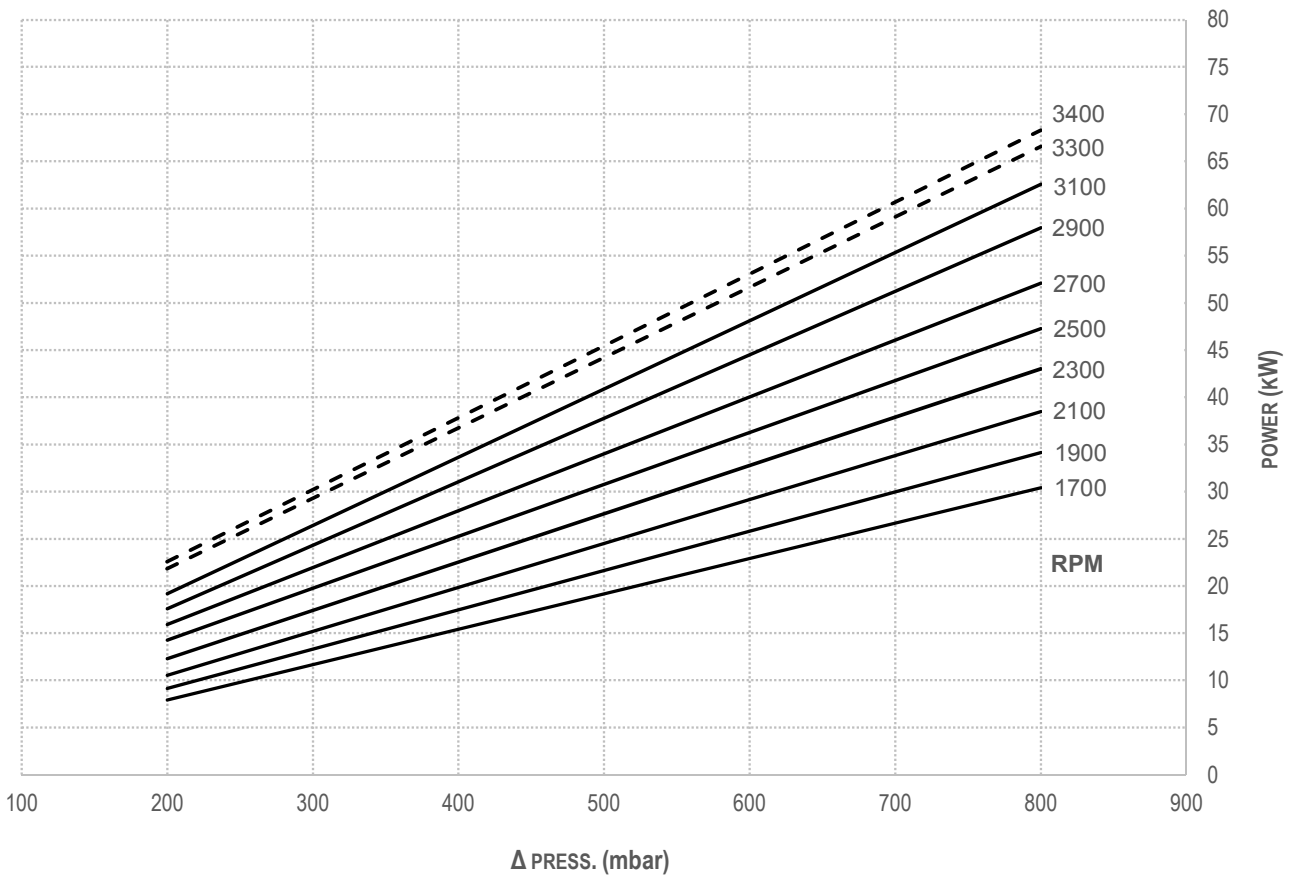
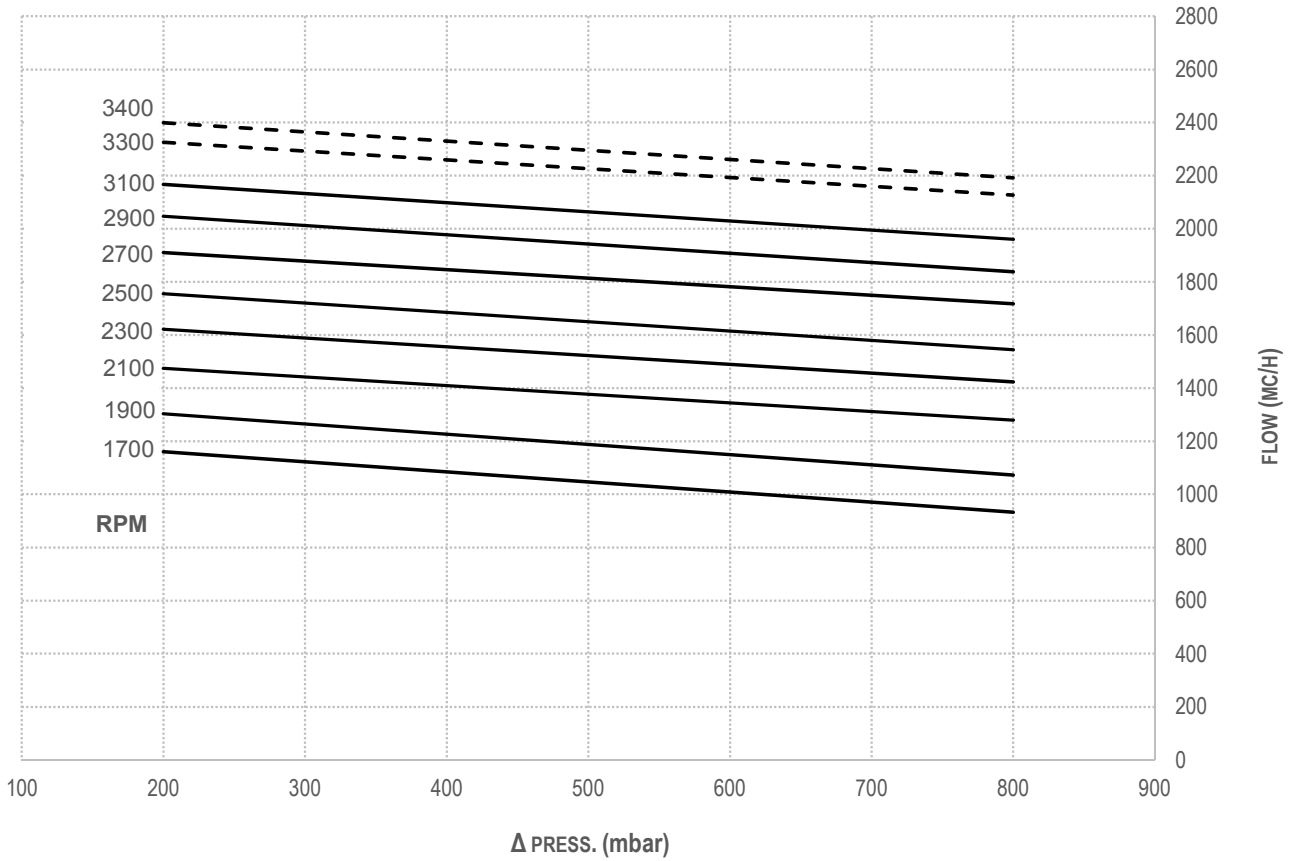

PVT 700

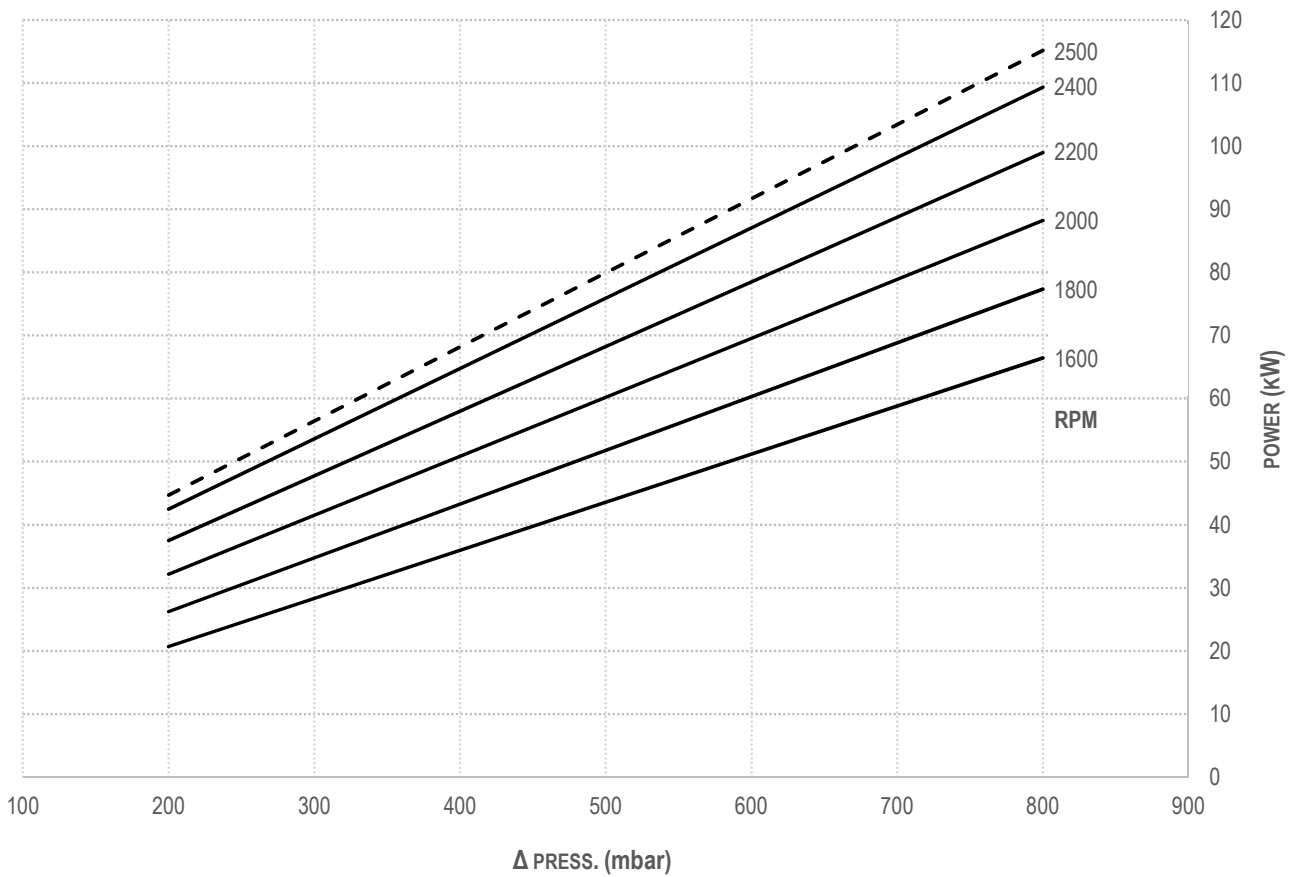
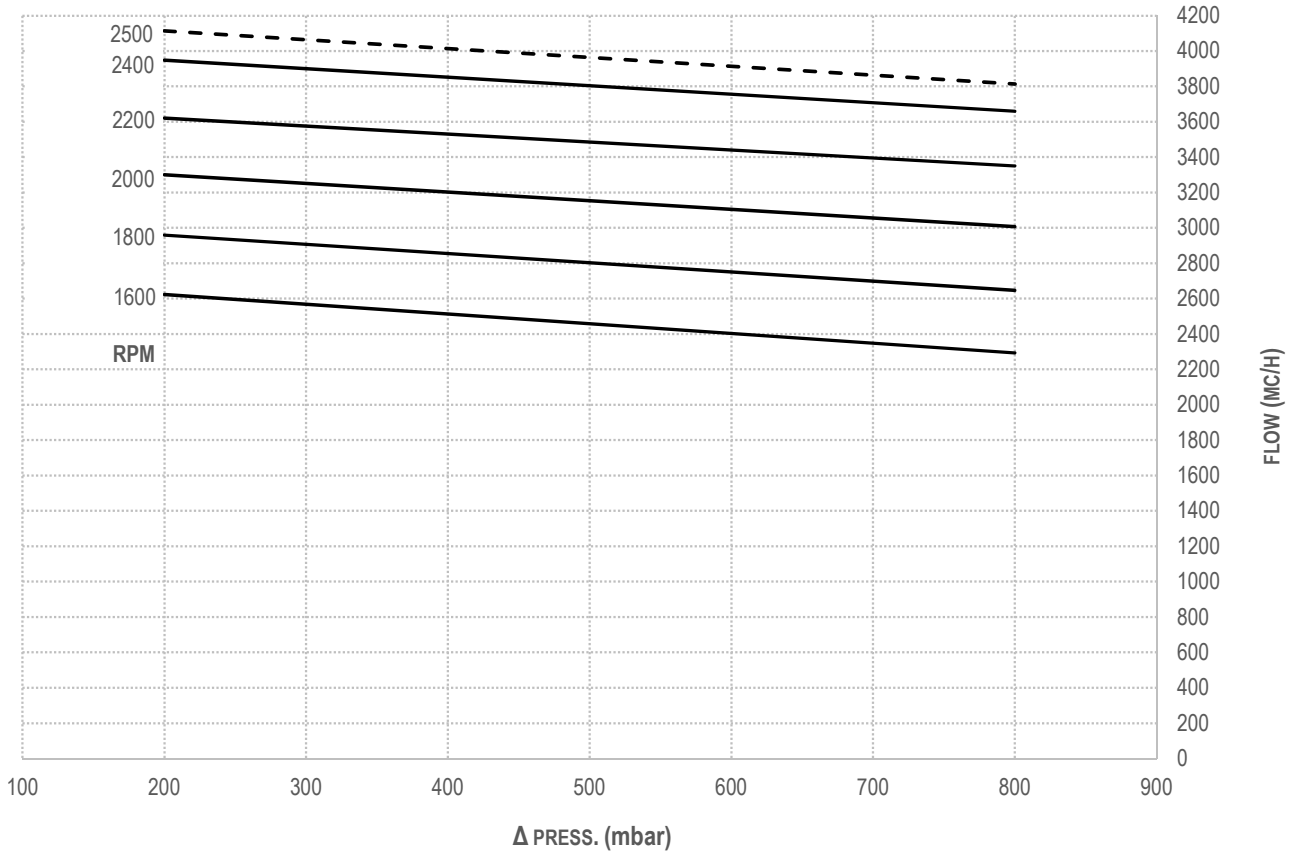

PVT 1000

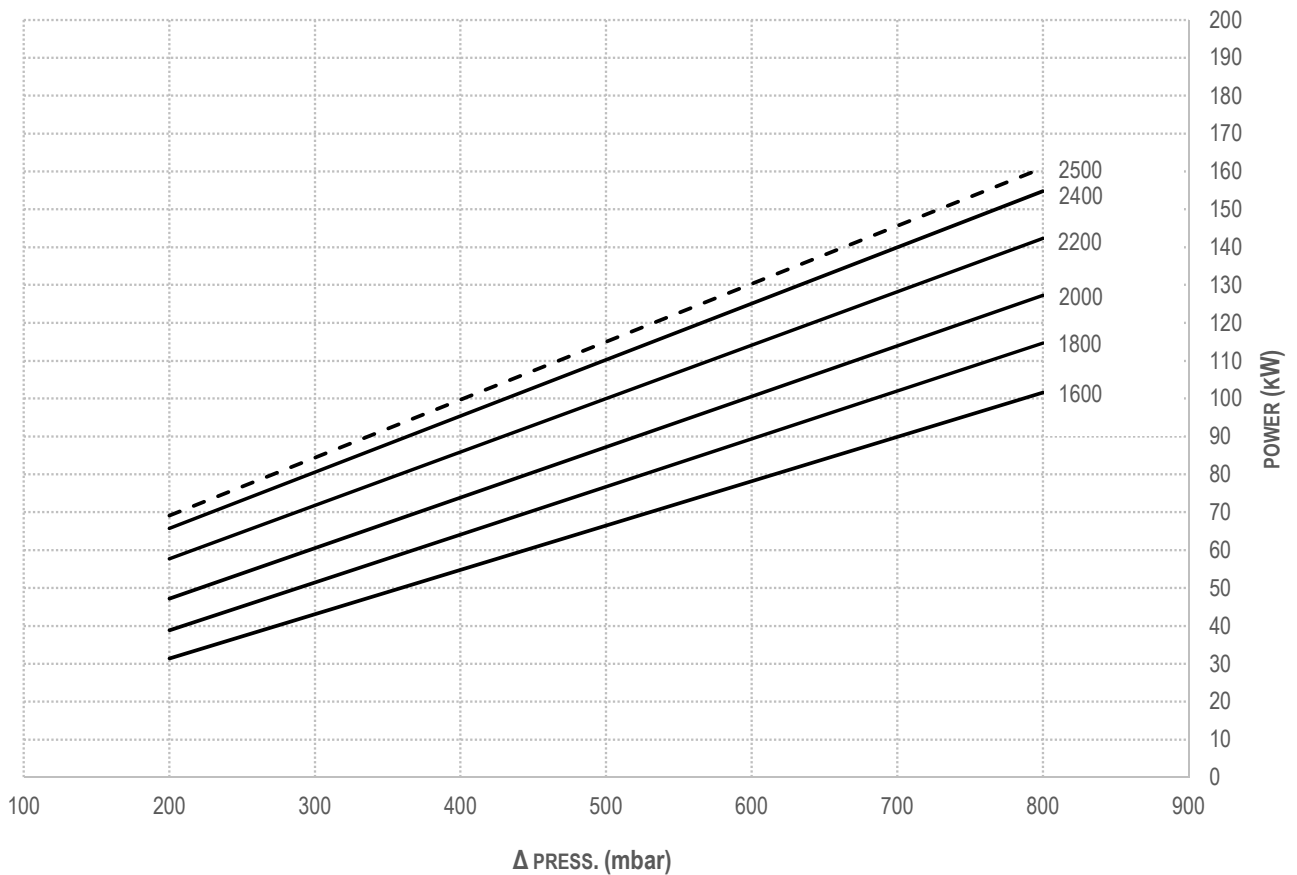
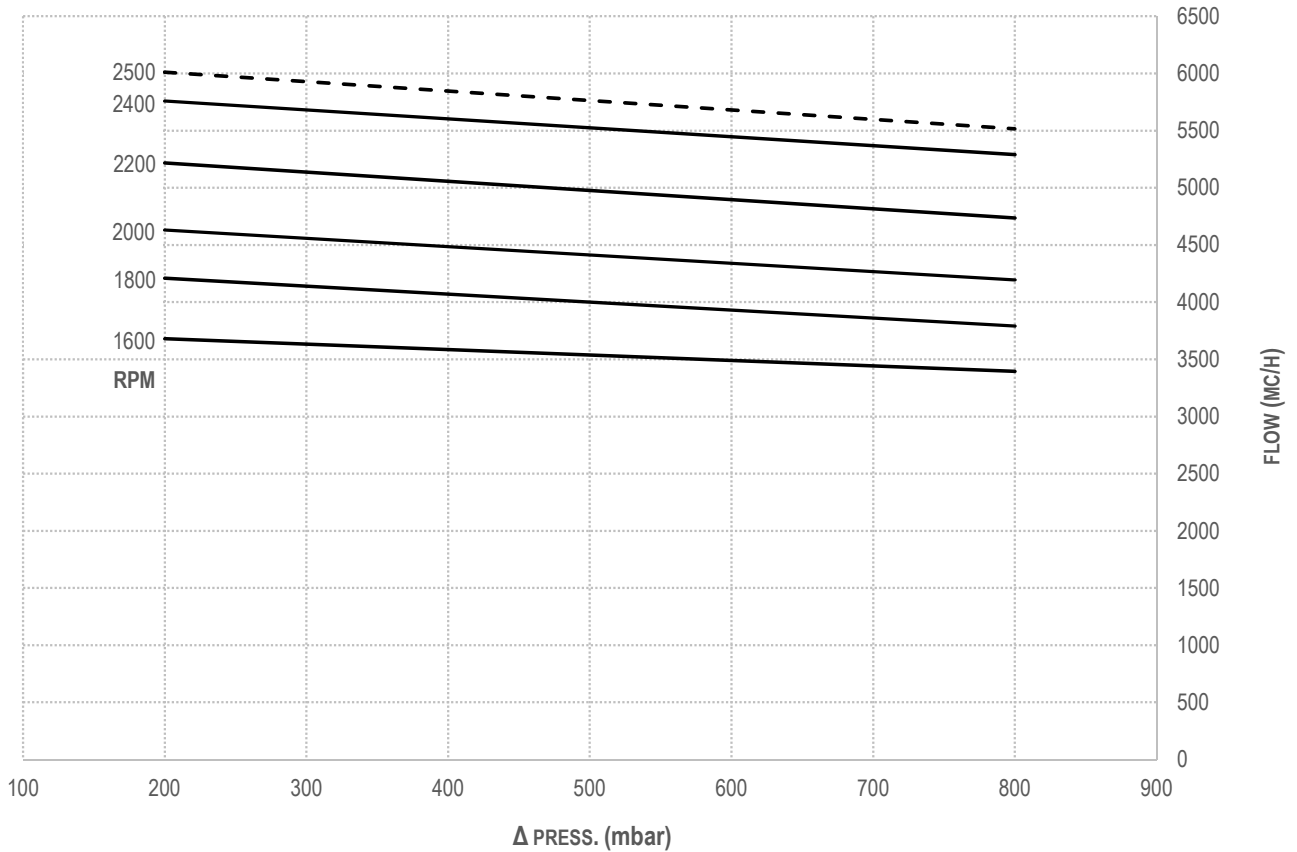

## 2.5 Noise level

Potoise power **L<sub>w</sub>A** of the pump only and relative noise pressure **L<sub>p</sub>A** in free field, at 7m from the pump

Measures according to: UNI EN ISO 9614-2

Measure tolerance: ±2%

PVT 200				
Rotation Speed [rpm]	Vacuum/Pressure	L <sub>w</sub> (A)		L <sub>p</sub> (A)
		Noise power of the only pump. (without drive trasmission suction group, silencers). [dB(A)]		Noise pressure of the only pump at 7m in free field. (without drive trasmission suction group, silencers). [dB(A)]
3300	vac 50%	91		63
	vac 80%	92		64
	Δ press 600 mbar	97		69
3600	vac 50%	92		64
	vac 80%	93		65
	Δ press 600 mbar	98		70
3900	vac 50%	95		67
	vac 80%	96		68
	Δ press 600 mbar	100		72
4200	vac 50%	96		68
	vac 80%	97		69
	Δ press 600 mbar	103		75

PVT 200 Multiplicatore				
Rotation Speed [rpm]	Vacuum/Pressure	L <sub>w</sub> (A)		L <sub>p</sub> (A)
		Noise power of the only pump. (without drive trasmission suction group, silencers). [dB(A)]		Noise pressure of the only pump at 7m in free field. (without drive trasmission suction group, silencers). [dB(A)]
1100	vac 50%	92		64
	vac 80%	93		65
	Δ press 600 mbar	97		69
1200	vac 50%	93		65
	vac 80%	94		66
	Δ press 600 mbar	98		70
1300	vac 50%	96		68
	vac 80%	97		69
	Δ press 600 mbar	101		73
1400	vac 50%	97		69
	vac 80%	98		70
	Δ press 600 mbar	104		76

**PVT 280 - 400**

Rotation Speed [rpm]	Vacuum/Pressure	Lw (A) Noise power of the only pump. (without drive transmission suction group, silencers). [dB(A)]		Lp (A) Noise pressure of the only pump at 7m in free field. (without drive transmission suction group, silencers). [dB(A)]	
		PVT280	PVT400	PVT280	PVT400
2300	vac 50%	92	93	64	65
	vac 80%	94	95	66	67
	Δ press 600 mbar	114	115	86	87
2500	vac 50%	94	95	66	67
	vac 80%	95	96	67	68
	Δ press 600 mbar	117	118	89	90
2700	vac 50%	95	96	67	68
	vac 80%	96	97	68	69
	Δ press 600 mbar	120	121	92	93
2900	vac 50%	97	98	69	70
	vac 80%	98	99	70	71
	Δ press 600 mbar	123	124	95	96
3100	vac 50%	98	99	70	71
	vac 80%	99	100	71	72
	Δ press 600 mbar	125	126	97	98
3300	vac 50%	99	100	71	72
	vac 80%	100	101	72	73
	Δ press 600 mbar	128	129	100	101

**PVT 700 - 1000**

Rotation Speed [rpm]	Vacuum/Pressure	Lw (A) Noise power of the only pump. (without drive transmission suction group, silencers). [dB(A)]		Lp (A) Noise pressure of the only pump at 7m in free field. (without drive transmission suction group, silencers). [dB(A)]	
		PVT700	PVT1000	PVT700	PVT1000
1200	vac 50%	98	99	70	72
	vac 80%	99	100	71	73
	Δ press 600 mbar	104	105	76	78
1600	vac 50%	101	102	73	75
	vac 80%	102	103	74	76
	Δ press 600 mbar	106	107	78	80
2000	vac 50%	104	105	76	78
	vac 80%	106	107	78	80
	Δ press 600 mbar	109	110	81	83
2400	vac 50%	107	108	79	81
	vac 80%	109	110	81	83
	Δ press 600 mbar	113	112	85	87

## 2.6 Usage limitations

Model	rpm		P <sub>2</sub> (bar rel.) max		P <sub>2</sub> -P <sub>1</sub> (bar)	T <sub>2</sub> (°C)	T <sub>2</sub> - T <sub>1</sub> (°C)
	Min	Max	Max continuos	Max intermittent	Max	Max	Max
PVT 200	2500	4200	0,8	1	1	160	130
PVT 200 M	833	1400	0,8	1	1	160	130
PVT 280 - 400	1700	3300	0,8	1	1	160	130
PVT 700 - 1000	1000	2400	0,8	1	1	160	130

P<sub>1</sub>: inlet absolute pressure

T<sub>1</sub>: inlet air temperature

P<sub>2</sub>: max continuos: pressure limit for continuos duty

P<sub>2</sub>: outlet absolute pressure

T<sub>2</sub>: outlet air temperature

P<sub>2</sub> max intermittent: pressure limit for intermittent duty

Vacuum operation: MAX counter pressure discharge + 0.1 bar

Under pressure operation: MAX vacuum value suction - 0.1 bar

## 2.7 Lubrication

Recommended lubricant: synthetic gear oil: **TENNEX FACTOR SYNT ISO 150**. In case this oil is not available, it is possible to refill the level with a gear oil composed of polyalphaolefine PAO.

Viscosity	Temperature	ENI	ESSO	SHELL	TOTAL	MOBIL	BP
ISO VG 150	Da -15°C a +40°C	BLASIA SX 100	MOBIL SHC 629	OMAL OILS RL 150	CARTER SH 150	SHC 629	ENERSYN HTX 150

### 3. Safety and accident prevention



**Attention: carefully apply these prescriptions.**

#### 3.1 General recommendations

- When transporting the pump, use proper slinging. Store the compressor in stable places.
- Installation and maintenance must be carried out with the unit totally disengaged from its drive system and must be performed by qualified personnel.
- Use adequate clothing (avoid ties, loose sleeves, necklaces and so on) and suitable protection equipment (gloves, protection glasses, boots...).
- Before each maintenance operation, stop the pump and restore the atmospheric pressure.
- Make sure that all the parts of the unit are idle and cool, before performing any maintenance operation.
- To prevent errors and hazardous situations, establish what each operator is responsible for in the different maintenance operations.
- Do not start the machine if the protection devices provided for transmissions are removed. Replace damaged parts.
- Final manufacturer must make the transmission inaccessible by means of a fixed guard or interlocked movable guard.
- Operators working nearby must avoid prolonged exposure to the noise emitted by the aspirator, if not equipped with the proper ear-protection devices. IPDs recommended: ear protectors.
- When the pump is running, some parts may reach very high temperatures (above 70°C). Use all necessary precautions to avoid contact.
- Avoid accidental suction of solids: solids may be projected at high speed through the exhaust manifold and cause injuries.
- Pressure relief valve: point the air flux away from the operators.
- Do not use the aspirator over its designed limits: the machine may be damaged and the operator may be injured.



**Do not exceed the power supply parameters indicated in the technical tables (see paragraph 2.3 - 2.6).**

- Based on the final use of the decompressor, the insertion in the housing machine and the typology of the same, the designer of the housing machine must apply safety signals (pictograms) to warn the operator on the risk still present. These pictograms essentially refer to three categories:
  - Signals prescribing the use of Individual Protection Devices (IPDs) such as, in this case, the use of gloves and ear protectors.
  - Signals indicating to pay particular attention to the dangers related to the machine's components, such as: risk of dragging in the transmission equipment and contact with hot surfaces.
  - Signals indicating specific parts of the machine for an easier identification, such as: greasing points, oil tanks, etc.

#### 3.2 Intended use

- PVT pumps are 3 lobe blowers specifically designed for vacuum plants that must convey gas free from polluting substances, oil or water: this is made possible due to the lack of sliding parts, and therefore oil lubrication within the compression chambers.
- Liquids or solids infiltrations can seriously damage the machine.
- Do not sack toxic substances and inflammable or explosive gasses, since the internal components of the pump may reach high temperatures.



**Do not sack toxic substances and inflammable or explosive gasses, since the internal components of the compressor may reach high temperatures.**

- Liquids or solids infiltrations can seriously damage the pump.



**Attention: liquids or solids infiltrations can seriously damage the pump.**

- Do not run the pump over its designed operating limits (see par. 2.3 - 2.6): it may break and transmission can be damaged.

#### 3.3 Conveyed fluids

- PVT pumps are suitable for conveying filtered air. Before conveying other kind of gases, verify compatibility with compressor's characteristics.
- Please contact JUROP's Technical dept. if necessary.



## 4. Installation

### 4.1 Compulsory accessories

- The correct installation of PVT pumps requires the following accessories:
  - Suction silencer for the injection system: use the specific PVT silencer.
  - Exhaust silencer.
  - Overheating alarm to connect to the thermostat on the exhaust port.
  - Undersigned suction filter on the vacuum line to avoid suction of foreign bodies or liquids.
  - Adequate overpressure safety valves.

Model	Air filter	Spark arrestor ATEX
PVT200	1445002900	14450MNZB0
PVT280-400	1445003200	14450GU6B0
PVT700-1000	145006800	14450HYJB0

### 4.2 Checking upon receipt

- When the goods are delivered, make sure that all parts listed on the delivery note are in perfect condition and have suffered no damage during shipping.
  - Remove the parts of the packaging that can be dangerous if sucked by the pump.
  - Make sure the pump has its identification plate affixed on the front cover. Pump without such identification are to be considered anonymous and potentially dangerous: in such an event, they must not be used, otherwise the manufacturer will be deemed free from any liability whatsoever.

### 4.3 Storing in the warehouse

- If the compressor will not be installed inside a short time after delivery:
  - Remove the guards from the ports and spray a film of protective oil over the inner surfaces of the body, rotors and sides. Then attach again the guards;
  - Store in a closed and dry place. Renew the preserving oil periodically.

### 4.4 Handling and installation

- Before each movement, verify that the lifting equipment has a suitable capacity (check the weight of the decompressor, possibly showed in this manual, in the paragraphs).
- Do not lift the packaging or the machine when moving more than 50 cm from the ground. Proceed with the final lifting only near the installation point.
- Harness the machine with suitable straps / chains near the main body, paying attention to the position of the mass centre of gravity to ensure the load stability.

**Warning: do not stand under the machine when it is lifted during the installation.**

### 4.5 Mounting

- When the pump is installed it must be accessible for maintenance and fitted, with vibration adsorbing pads, to a bearing frame or level base (**Max. admitted angle 3° in all the directions**).
- The size of the frame must be suitable to support the pump weight and avoid bending. It is recommended to install the pump on vibration adsorbing pads to reduce the noise and vibrations produced during its operation.
  - Leave enough space around the pump to allow the free circulation of air for cooling; avoid exposure to dirt and debris.
  - Leave enough room to access the oil drainage, filling and checking ports (see Pic. 4.1).
  - The oil level control and drainage plugs are mounted correctly during the final inspection in the factory. Do not change their position.

Legend	
L	oil level (front and rear gearboxes)
SO	oil drainage (front and rear gearboxes)
SS	gearbox vent (front and rear gearboxes)
ST	seals vent (front and rear gearboxes)
CO	filler cap (front and rear gearboxes)
FD	drainage hole

PVT - HORIZONTAL PORTS

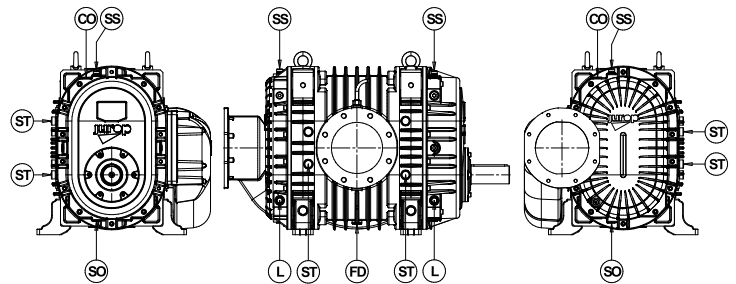

PVT - VERTICAL PORTS

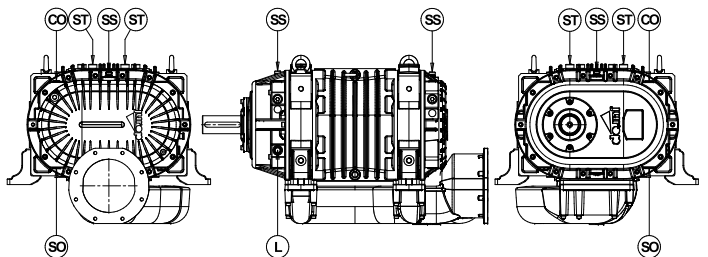

PVT – WITH MULTIPLIER

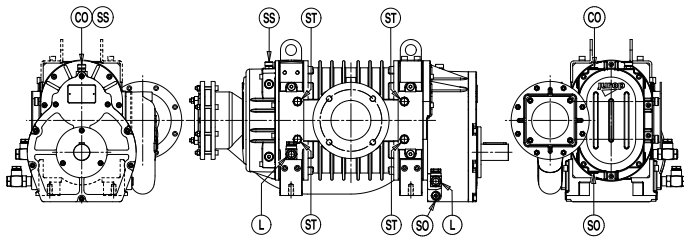

Pic. 4.1

• Oil levels, filler caps and oil drainages are individual for the front and rear gearboxes.



**Oil levels, filler caps and oil drainages are individual for the front and rear gearboxes.**

• The vacuum pump's rotation direction determines the room taken up by the injection system and flow direction (see the paragraph 2.2). Any changes made to rotation direction or to the assembly position must be agreed with our Technical Assistance.



**Any changes made to rotation direction or to the assembly position must be agreed with our Technical Assistance.**

- Keep suction filter clean: obstructions may lead to noticeably reduced performance
- Keep injection filter clean: obstructions may reduce the air injection cooling performance and cause overheating of the pump.
- Do not embed nor cover the pump.
- The base must not lead heat towards the machine while it is running.
- In the event that the decompressor is electrically isolated, connect it to the ground or make it equipotential with the housing machine. Check that the paint does not prevent its passage.

**Vacuum/Pressure Line – Vacuum operation**

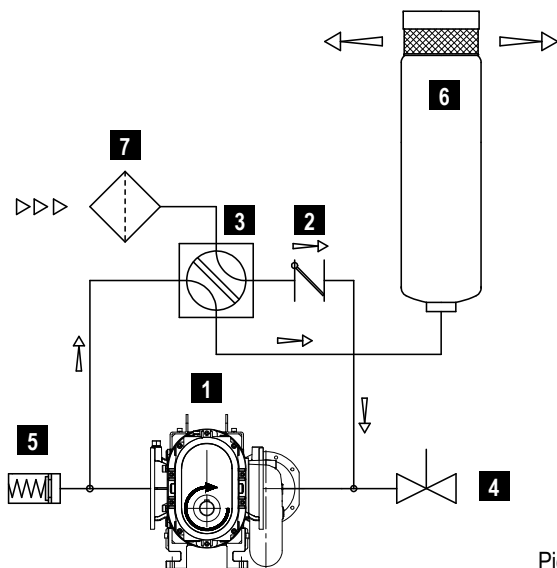

Pic. 4.2

**4.6 Vacuum – pressure line**

- See figures 4.2 e 4.3.
- The diameter of the vacuum and pressure line pipes must be suitable for the pump's flow rate (approximate average air speed is 15-30 m/s); in any case, it should not be smaller than the ports diameter.
- The weight or dimensions of the pipes must in no way stress the vacuum pump body. Use high temperature resistant rubber sleeves.
- Remove the port guards when mounting. The pipes and components of the whole line must be clean.
- Avoid constrictions and tight curves where they are not essential.
- The exhaust pipes can reach high temperatures. Protect those adequately from the operator reach.
- A clapet valve on suction pipe avoids rotation in the opposite direction when the vacuum pump stops.
- Over-pressure safety relief valve on the vacuum line: install it close to the vacuum pump. Valve relief flow rate must limits the PVT400 from exceeding a pressure of 1800 mbar or, in any case, the maximum allowed by the system (see par. 2.6). Do not interpose shutoff valves on the line between the pump and the safety relief valve.
- If necessary apply:
  - A second shutoff valve or suction filter. Liquids and materials must never reach the pump;
  - A venting valve on the suction line, controlled by the thermostat: when the vacuum pump is overheating, this valve will open a direct connection with the atmosphere and consequently the pump will suck fresh air ,from the outside, for a better cooling (a 2" valve size can be enough for a good cooling without losing too much vacuum rate). Install a silencer filter;
  - A 4-way change-over valve to obtain alternatively vacuum or pressure in the system (this is not required if the pump is used only for vacuum or only for pressure).

**Vacuum/Pressure Line – Pressure operation**

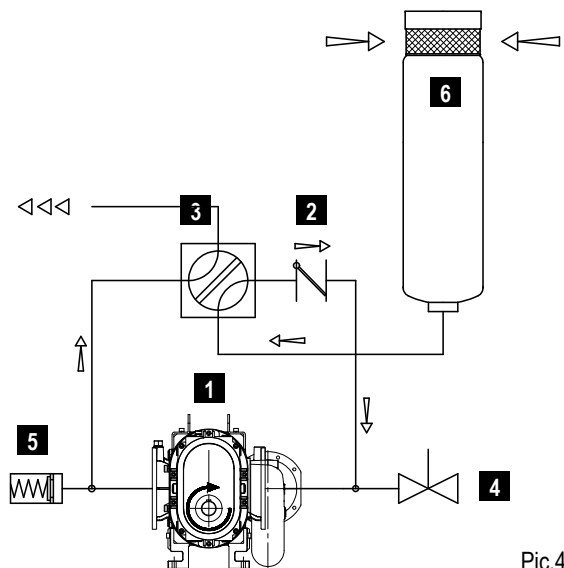

Pic.4.3

**Vacuum/Pressure Line components**

1	Vacuum Pump	5	Over-pressure safety relief valve
2	Clapet valve	6	Silencer
3	4-way change-over valve (optional)	7	Suction filter
4	Overheating safety venting valve (optional)		

- Turning of 90 deg. (from the vacuum position) the 4-way valve changeover, the pump can suck air from the exhaust silencer to pressurize the tank. In this case it is recommended to control the pump speed in order to avoid dangerous overpressure in the line.

- In case of overheating working under pressure condition, opening of the safety venting valve mounted on suction line will not cool down the pump. The only possible solution is to stop the pump drive and wait for a proper cooling.

- The clapet valve, on the suction line, avoids opposite rotation of the vacuum pump when it is stopped under vacuum conditions:

- Before servicing the vacuum pump or its drive system. The pressure difference between inlet/outlet ports can start the machine turning automatically;
- Before starting the machine again: otherwise it would require a higher starting torque.

**Attention: when pump is stopped under load, vent the system before any maintenance operation.**

**4.7 Air injection cooling system**

- Operating only in the vacuum mode.
- Use only the specific air injection silencer for the PVT, standard or compact.
- The minimum pipeline inner diameter (Di) of the injection system must be:

Model	Inner diameter
PVT 200	98 mm
PVT280	110 mm
PVT 400	127 mm
PVT 700	160 mm
PVT 1000	190 mm

- The silencer should be mounted as close as possible to the vacuum pump (max. 1-1.5 m) and in a position protected against debris and water:

- Avoid tight curves;
- Avoid pumping nearby heat sources;
- Check the flow direction and the clapet valve positioning.

- Check weekly the cleanliness of the silencer suction port. Remove all the filth that obstruct the air flow.

- An inefficient AIR injection could cause the vacuum pump overheating during the vacuum operation.

**Attention: an inefficient AIR injection could cause the vacuum pump overheating during the vacuum operation.**

- Max injection line vacuum value: - 0.1 bar. Measurement taken near the pump injection vent.

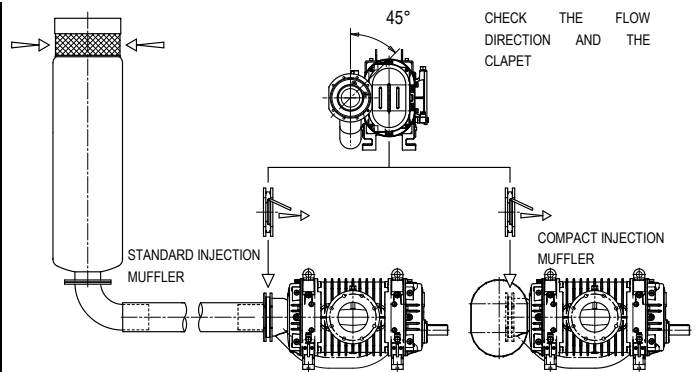

Pic. 4.4

**4.8 Overheating alarm**

- The vacuum pump is supplied with a thermostatic switch on the exhaust port. When reaching the maximum allowed temperature, the switch must send an electric signal to the alarm system or open a valve on the suction line, to let the fresh air coming in and cool the pump.

- Electric characteristics of the SPDT connector:

- a. DC power supply: max 220V, 12W dc-13 (control coils data).
- b. AC power supply:
  - max 440V, 10A ca-1 (resistive load);
  - max 440V, 6A ca-3 (start-stop for asynchronous motors);
  - max 440V, 4A ca-15 (power supply with control coils power supply with control coils > 72VA).

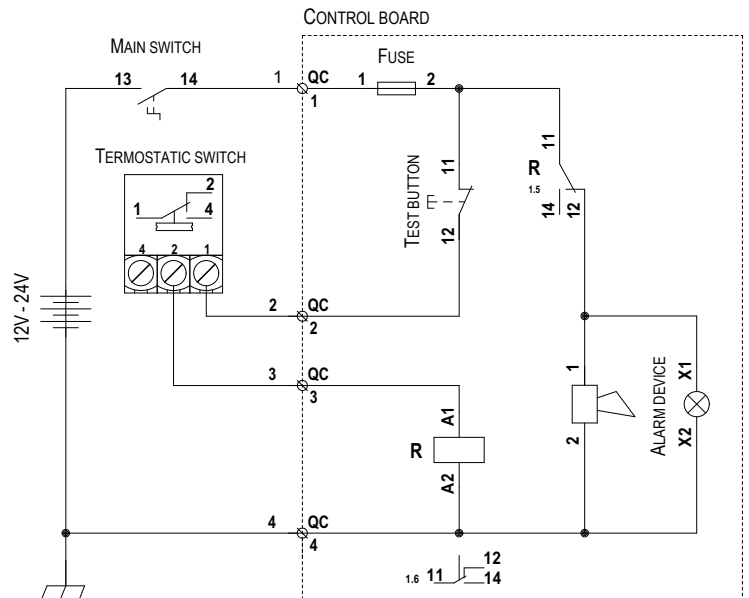

- c. Protection: IP67 (IEC 529 and DIN 40050).
- d. Room temperature: from -40 to +70°C.
- e. Core hitch: Pg 13.5 for cables from 5 to 14 mm.

- Use the NC (normally closed) contact of the switch to control the coils of a power relay. In this way (see above diagram) the alarm

advises also in case of accidental wires damage (safety protection of the circuit).

• Sensor installation:

1. The sensor of the thermostat is supplied by us already fitted inside its housing. In case of disassembling, follow the instruction (above drawing) to reassemble.
2. Unwind the protected capillary of the sensor avoiding tight curves or buckling. Fix the unit to a stable support before proceeding (to avoid vibrations or accidental impacts).
3. The thermostat operation can be influenced by the ambient temperature. The setting made by the manufacturer is correct to work in ambient temperatures between 0°C and 40°C. If the thermostat is frequently used over said temperature range, it could be necessary a new setting. Please contact the after sale technical service.

• Check the following points to grant a correct operation of the thermostat:

1. The spacer sheet keeps the sensor fitted on the lowest part of its housing.
  2. The fitting sheet must fill the clearance between the sensor and its seat in the housing; this is important to grant an easy and correct heat transmission.
- Overheating can seize the vacuum pump, causing a damage also in the drive line. Stop the pump for cooling or drive it at free ports conditions (with the suction valves fully opened) to let it cool down properly. The pump can be again operated only when the alarm is turned off after cooling.

**Attention: overheating can seize the vacuum pump, causing a damage also in the drive line.**

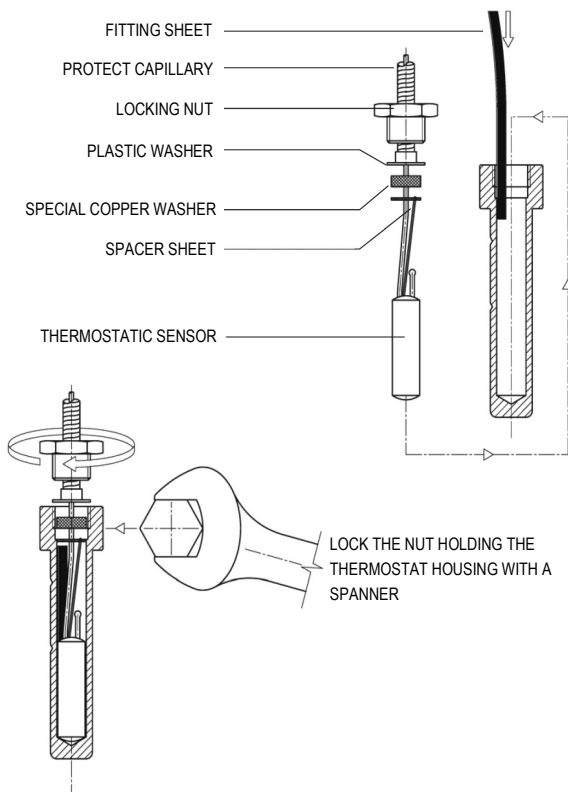

Pic. 4.5

#### 4.9 Oil level alarm (optional)

• The vacuum pump can be supplied with two optical oil level switches, one in the front gearbox and one in the rear gearbox. When reaching the minimum oil level necessary for the gears lubrication in one of the gearboxes, the switch must send an electric signal to the alarm system.

• Electric characteristics of the K11 oil level switch:

- a. DC power supply: 10-28 V;
- b. AC power supply: 24 V;
- c. Protection: IP65 (IEC 529 and DIN 40050);
- d. Room temperature: from -40 to +125°C.

• Use the NC (normally closed) contact of the switch to control the coils of a power relay. In this way (see above diagram) the alarm advises also in case of accidental wires damage (safety protection of the circuit).

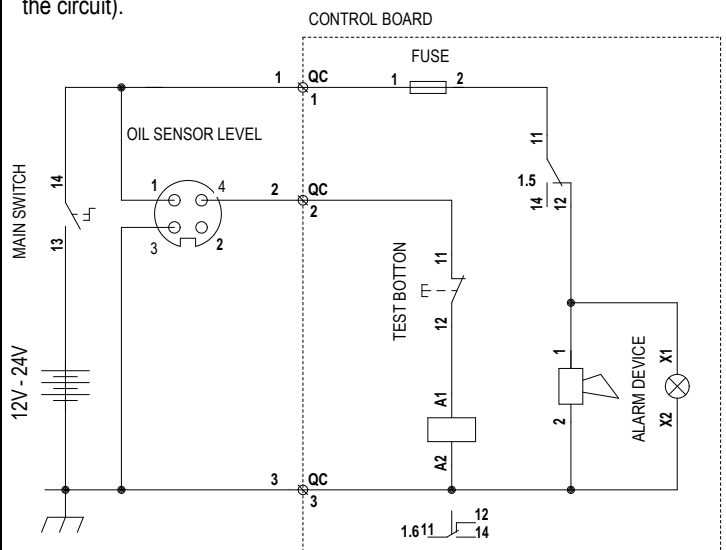

• Working with an oil level lower than the minimum recommended leads to a rapid wear of internal seals, bearings and gears causing the seize of the vacuum pump.

**Attention: working with an oil level lower than the minimum recommended leads to a rapid wear of internal seals, bearings and gears causing the seize of the vacuum pump.**

• Stop the vacuum pump and refill both the gearboxes with the recommended oil (see par. 2.7).

#### 4.10 Drive system

• For the machines of this series, the allowed power transmissions are:

- Direct transmission;
- Oil hydraulic transmission (HDR).

##### A) Belt drive

• Install a suitable pulley on the smooth shaft as close as possible to the pump in order to avoid excessive bending stress on the drive shaft.

- Install a suitable pulley on the smooth shaft as close as possible to the compressor. Taper lock pulley are suggested.
- Do not use driven or driving pulleys with a pitch diameter inferior to values reported in the box below. Small pulleys require a high belt tension which may cause premature wear to the bearing or transmission damages.
- Let the air circulate freely to cool down the pump.
- A limited speed ratio will extend the belts life and reduce stress on the shafts. When possible prefer:
  - Pulleys with a pitch diameter bigger than the one indicated;
  - Engines or power take-offs with a speed similar to the one of the vacuum pump.

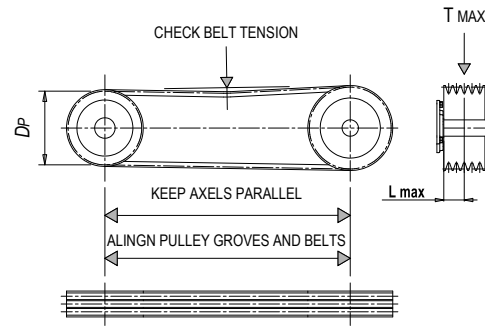

Pic. 4.6

Model	Max Speed (rpm)	T. max (N)	L. max (mm)	Pd Min. Transmission (mm)	N° grooves	Belt Type
PVT 200	4200	3000	50	160	4 x SPA	XPA
PVT 200 MOLT.	1400	3800	35	250	4 x SPB	XPB
PVT 280	3300	3500	45	180	4 x SPB	XPB
PVT 400	< 2800	5000	55	160	5 x SPB	XPB
PVT 400	> 2800 (MAX 3000)	5000	55	180	5 x SPB	XPB
PVT 700	2500	6500	75	250	4 x SPC	XPC
PVT 1000	2500	11500	87	250	5 x SPC	XPC

Dp. min.: minimum pitch diameter of small pulley.

**B) Hydraulic drive**

- The PVT HDR vacuum pump is completed with a fixed displacement high pressure motor suitable for open or closed type oil circuits.

Model	Displacement (cc/rev)	Max working pressure (bar)	Max drainage line press. (bar)	Fluid	Filtering Class	Optimal viscosity cSt	Max viscosity cSt	Max T° oil °C (*)
PVT 200 HDR	19.6	350	1.5	HL/HM	21/19/16	15 - 40	800	90
PVT 280 HDR	40	410	1	HLP	20/18/13	15 - 30	1000	80
PVT 400 HDR	60	420	1,5	HLP	20/18/13	15 - 30	1000	90
PVT 700 HDR	90	350	1	HLP	20/18/13	15 - 30	1000	80
PVT 1000 HDR	125	400	2	HLP	20/18/13	15 - 30	1000	90

(\*) : Value reported to the main circuit.

- **Oil flow and pressure:** to be defined according to the vacuum pump speed rotation.
- **Fluid:** mineral oil for hydraulic systems HLP (DIN51524) and HL/HM (ISO6743-4).
- **Filtering:** class 21/19/16 (PVT200) and class 20/18/13 (PVT280-400-700-1000) according ISO 4406.
- **Check the oil line connections** that must logically following the rotation direction of the vacuum pump (see Pic. 4.7).

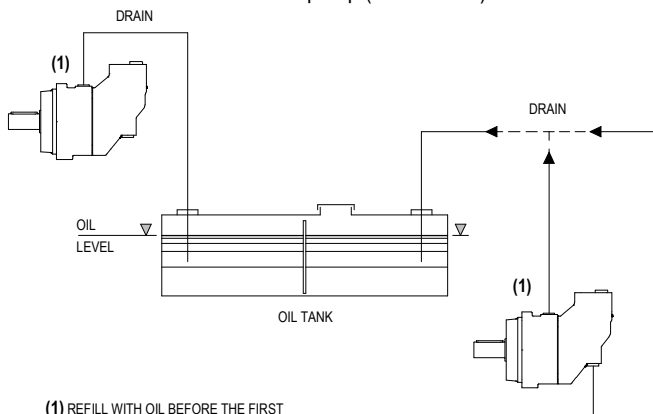

Pic. 4.7

- **Drainage:** connect this line to the oil tank to make sure the motor never operates without oil. Discharge into the tank under free surface or bend the pipe into a U-shape.

Model	Drain threaded	In/Out Flange
PVT 200 HDR	G 3/8	SAE 3/4" 6000 psi
PVT 280 HDR	M18x1.5	SAE 3/4" 6000 psi
PVT 400 HDR	M22x1.5	SAE 3/4" 6000 psi
PVT 700 HDR	M22x1.5	SAE 1" 6000 psi
PVT 1000 HDR	M22x1.5	SAE 1 1/4" 6000 psi

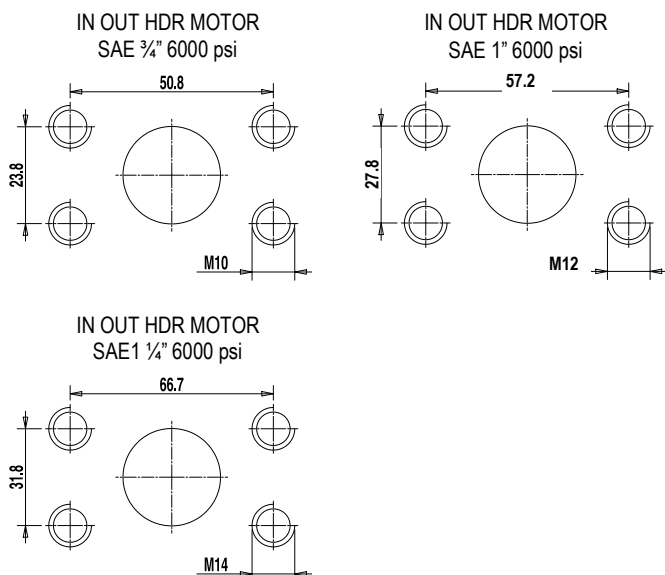

- **Starting-up:** be sure that the system is well cleaned and pour oil into the tank and into the motor housing (necessary to lubricate the internal bearings).
- Vent the circuit and adjust the overpressure safety valve to the lowest possible value.
- Check the oil tank level.
- Increase pressure and rotation speed until operating values are reached.

- It is recommended to avoid rotation in the opposite direction when the vacuum pump stops; this because it could damage the hydraulic motor whether the circuits are open or closed (see also the “Vacuum – Pressure Line” paragraph). The hydraulic circuit must be protected against overpressures.



**Attention: avoid rotation in the opposite direction when vacuum pump stops; this because it could damage the hydraulic motor.**

- Check the rotation speed, using the inductive sensor mounted on the hyd. motor bracket. Connect it to an electronic rev counter, suitable for 2 kHz max inductive sensors, and set the teeth number at z.
- The inductive sensor must be powered at 12-24V DC from the rev counter.

Model	Z (teeth n. of the inductive sensor gear)
PVT 200 - 400 HDR	4
PVT 700 - 1000 HDR	2

- The machine/system manufacturer is responsible for dimensioning the lines.



**The machine/system manufacturer is responsible for dimensioning the lines.**

## 5. Start up

### 5.1 Starting-up

- Check the oil level, in the front and rear gearboxes.
- Check that all protection devices are correctly installed.
- Check that there are no obstacles in the vacuum/pressure line.
- Check rotation direction: open all system valves and start running slowly.
- Rotation in the wrong direction is allowed at slow speed: possible damage to the line and/or pump.



**Attention: rotation in the wrong direction is allowed at slow speed: possible damage to the line and/or pump.**

- Close the valves and increase pressure or vacuum rate.
- Check speed under load and operation: absence of anomalous noise or vibrations.

### 5.2 Operating suggestions

- The manufacturer declines all responsibility for damages caused if the installation, operating and maintenance instructions are disregarded.
- When the overheating alarm advises (optional) the operator that the maximum operating temperature has been reached:
  1. Stop the pump and wait until it has cooled down.
  2. If possible drive it with all the valves opened for the time necessary to a proper pump cooling, run the pump at a vacuum

rate lower than 30% - if working in vacuum mode - or at an exhaust pressure lower than 200 mbar rel. - if working in pressure mode - for the time necessary to restore the alarm. To this purpose, provide an adequate opening which is in communication with the atmosphere on the suction/discharge line and is operated by a valve regulated by the alarm system itself.

3. Work can be started again only when the temperature has returned to normal values.
4. If the alarm triggers often during normal use, it is necessary to check the conditions of use (temperature, pressures, speed) and the conditions of the system.

- When ambient temperatures are very low (like in the winter for instance), exhaust temperatures are lower than usual and the overheating alarm does not advise even if you are working at high speed and with high vacuum levels. We recommend not to exceed a temperature difference of 130°C between incoming and outgoing air, to avoid anomalous deformation of the components and block/seize the vacuum pump. Avoid continuous duty under such conditions even if the overheating alarm does not trigger.

- After operation in dusty environments, after accidental sucking of liquids inside the pump or before a long inoperativity period it is recommended to wash the pump inside according to the following procedure:

1. Before washing the pump, be sure that it has cooled down. To obtain this in a short time, it is possible to run the pump for a few minutes at zero vacuum conditions, or stop it at all.

 **Attention: Do not carry out this operation on very hot pumps (for example after a working day) until they have cooled down.**

2. Use 1-2 liters of water mixed with a non-flammable detergent. We suggest some product like Henkel Bonderite C-NE 5225: 5% concentration in water. This detergent grants a good protection against rust and oxidation.
3. Use one of the openings placed in the vacuum line (closet on the pump) to suck some water mixed with detergent.
4. Start the pump at low speed (about 1000 rpm for PVT200-280-400 and 500 rpm for PVT200M-700-1000) leaving opened all the suction valves in the tank, in order to keep low the vacuum rate (max vac. 10-20%). Let the detergent mix entering the pump very slowly.
5. The detergent mix stays suspended in the pump inside, before being expelled through the exhaust silencer.
6. After keeping the pump speed for a while to make the product reaching the internal parts, it is necessary to dry the pump preventing oxidation. When the detergent mix is finished, continue running the pump at the lowest possible vacuum rate for a few minutes, then close venting and suction valves up to 50-60% maximum, for a couple of minutes. With this operation the pump will dry from the heated air and protected from the chemical attack of the detergent.
7. Washing the pump with this detergent guarantees a protection after some days of inoperativity. If the pump is not used for more

than two weeks, after having washed and dried the inner parts as described above, it is recommended to suck slowly 200 cc anti-rust and water-repellent protective oil (or, if not available, a very fluid gear oil).

 **Attention: do not carry out also this operation on very hot pumps (for example after a working day) until they have cooled down.**

 **Dispose of used oil in accordance with the current regulations.**

- Do not convey the exceeding flow outlet towards the suction port.
  - Control the air flow by adjusting the rotation speed: do not use the safety relief valve to discharge the exceeding flow.
  - Do not squeeze the hoses/pipes.
  - When stopping the pump, avoid rotation in the opposite direction.
- In fact, the difference in pressure between delivery and suction ports can make the rotors turning. Use non-return valves on the line.
- If the decompressor operates in vacuum or under pressure with a capacity environment (such as a cistern) and is not equipped with the "suction unit" accessory, it is advisable to intercept the working line of the machine when it is stopped, to prevent contrary rotations until the rebalancing of the pressures. The interception can take place through a controlled valve or an automatic unidirectional valve (swing valve).
  - Avoid starting the pump under load: motor and drive system can be excessively stressed.

## 6. Maintenance

### 6.1. Ordinary maintenance

- Any interventions must be performed when the machine is cold, stopped and switched off.
- Installation and maintenance must be operated only by qualified personnel wearing the proper clothes and the necessary tools as well as protection devices.
- Use suitable protection equipment (gloves, protection glasses, boots...).
- In the following table summarizes the main controls to be performed and the frequency of intervention.

Operating conditions	Area di intervento	Checking	8H	50H	500H	1000H
OPERATING	Vacuum line	Verifica efficienza valvole sicurezza (valvola non ritorno)				
		Working pressure				
	Transmission / Pump	Rotating speed				
		Noise (also HDR motor)				
		Temperature				
STANDSTILL	Vacuum line	Clean filter and vacuum line shutoff				
		4-way changeover valve (optional): check and lubricate				
	Pump	Oil level				
		Change oil in front gearbox (*)				
		Change oil in rear gearbox (*)				
		Pump's inner washing (**)				
	Overall	Check transmission pulley				

(\*) The first oil change must be done inside 500 hours operation. Following changes every 5000 hours or 12 months. In order to choose the most suitable oil, see paragraph 2.7.

(\*\*) After operation in dusty environments, after accidental sucking of liquids inside the pump or before a long inoperativity period it is recommended to wash the pump inside according to the procedure described at paragraph.

### Checking oil level rear and front gearbox

- Check the oil level in both gearboxes (front/rear) when the pump is still and cold. Oil sight, refill and drainage are showed in Pic. 4.1.
- The oil level must not drop below minimum: internal components may rapidly wear.

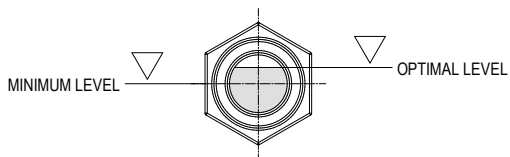

• The wearing of the internal lip seals will cause the level of oil in the boxes to drop. We strongly recommend that you often check the oil level - every day or at the latest every week - because frequent oil refilling indicates wearing of seals.

• Use synthetic gear oils: **“TENNEX FACTOR SYNT ISO”**.

• In case this oil is not available, it is possible to refill the level with a gear oil composed of polyalphaolefine (PAO), see par. 2.7.

• It is recommended to refill the oil level always with the same type: avoid mixing of various oil types.

• Check and change also the washer mounted with the discharge plug.



**Dispose of used oil in accordance with the current regulations.**

• Do not run the compressor with insufficient lubrication: that may cause seals and internal transmission members to wear quickly and/or the compressor to stop with possible breakdown of the drive system.

• Follow installer’s instructions for the checking and servicing of vacuum –pressure line components (filters, safety valves, seals, etc.) drive members (belts, hydraulic drive system, etc.) controlling and adjusting devices (revolution counters, sensors, etc).



**Follow installer’s instructions for the checking and servicing of vacuum –pressure line components, drive members, controlling and adjusting devices.**

Model	Arrangement	Front Gearbox (shaft side)	Rear Gearbox
PVT 200	Horizontal suction-discharge ports	0,4	0,55
	Vertical suction-discharge ports	0,6	0,9
PVT 200 MOLT.	Horizontal suction-discharge ports	1,1	0,55
PVT 280 - 400	Horizontal suction-discharge ports	0,65	0,5
	Vertical suction-discharge ports	1,2	0,9
PVT 700 - 1000	Horizontal suction-discharge ports	2	1,5
	Vertical suction-discharge ports	3,5	2,5

**Flushing-Kit (optional)**

• Use appropriate protective equipment (recommended IPDs: gloves and goggles).

• The flush kit is a specific tool for the maintenance of JUROP vacuum pumps. The regular use of the kit helps reducing the repair costs of the pump and increase its life span.

• It’s recommended to use the flush kit every week, possibly at the end of the working week or at any time the need arises. Use instructions:

1. Before doing this operation wait for the pump to cool down. Connect, if not already done, the flush kit near the blower suction manifold. The tank position must be possibly higher than the connection of the same with the pump.
  2. Start the pump at medium speed, under conditions of use close to the free vent.
  3. Open the ball valve in order to let the flushing fluid out. We suggest some product like Henkel BONDERITE C-NE 5225: 5% concentration in water.
  4. Flush about 0,2 litre before turning the ball valve off.
  5. Keep the blower running for one minute from the closing of the valve, letting the fluid drain out the pump.
  6. Turn the blower off.
  7. Drain the flushing liquid (FD plug, pic. 4.1) and dispose of it according to local regulations.
- To order spare parts see spare parts list at the end of this manual.

**6.2 Extraordinary maintenance**

• All extraordinary maintenance interventions must be carried out when the machine is cold, stopped and switched off. Implement the

safety instructions reported in the “Safety and accident prevention” Chapter, before performing any maintenance operation.

• Except for the cases described below, extraordinary maintenance on a PVT must be carried out by specialized personnel only; otherwise the guarantee will be invalidated.



**Follow the safety prescriptions as described in Cap. “Safety and accident prevention”.**

**Replacing the front sealing ring (PVT 200M, PVT 280, PVT 400, PVT 700, PVT 1000)**

• Replace it immediately in case lubricant leaks or every 5 years.



**Attention: Replace it immediately in case lubricant leaks or every 5 years.**

• See Pic. 6.1.

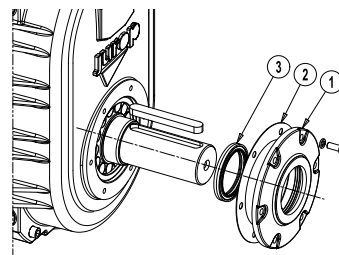

Pic. 6.1

- Remove the transmission.
- Clean the front flange (1) and remove.
- Replace the sealing ring (3). Spread the Y-seal lip with high temperature grease 220°C NLGI2.



- Change the gasket (2) and fit the flange back on its seat. Do not damage the sealing lip or turn it over when remounting.
- The housing seat of the tongue has sharp edges: pay attention.

Model	Gasket code (2)	Y-seal code (3)
PVT200 MOLT	1680708700	4022200412
PVT 280 - 400	1680708400	4022200425
PVT 700 - 1000	1680710500	4022200152
PVT 700 HDR	1680701400	4022200152

**Replacing the front Y-seal (PVT 200)**

- Replace it immediately in case lubricant leaks or every 5 years.

**Attention: Replace it immediately in case lubricant leaks or every 5 years.**

- See Pic. 6.2.
- Remove the transmission.
- Unscrew the drainage plug (SO) of the front cover and empty it.
- Remove the front cover.
- Replace the Y-seal (3). Spread the Y-seal lip with high temperature grease 220°C NLGI2.
- Change the gasket (2) and fit the flange back on its seat. Do not damage the seal lip or turn it over when remounting.
- The housing seat of the tongue has sharp edges: pay attention.
- Refill with oil (recommended synthetic gear oil) the front box. Check the oil level sight (L). See paragraph 4.4.

Model	Gasket code (2)	Y-seal code (3)
PVT 200	1680709600	4022200154

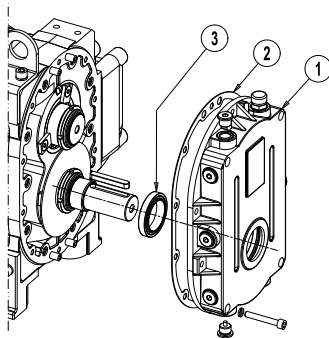

Pic. 6.2

**Common maintenance for all PVT**

**Cleaning the rotors and body**

- Is necessary to eliminate hard formations.
- Remove the pipes from the suction and exhaust ports.
- Clean the inside surface of the body and rotors with solvents and scrape without scratching.
- Drain the solvent used through the FD cap (Fig. 4.1). Dispose of in compliance with the standards in force.

**Checking the clapet valve on the injection**

- Check it periodically to avoid the accidental suction of solid particles inside the vacuum pump (See par. 4.6).
- Once a year: change the O rings.

- Once every 3 years: change the clapet and related screws and washers.

**Replacing the rock wool of the compact air injection silencer**

- It is possible to replace the internal rock wool of the compact injection silencer if its noise level increase. The spare part code of the rock wool is 40222 136 00 and the quantity is reported on the side table.

Model	Rock wool (kg)
PVT 200 - 200M - 280 - 400	2,5
PVT 700	8,5

- Remove the silencer cover.
- Extract the exhausted rock wool.
- Clean the internal surfaces of the silencer with a solvent.
- Insert the new rock wool.
- Check the cleanness of the internal air injection duct before closing the silencer with his cover.
- Close the silencer with his cover.

**Cleaning the seals venting plugs**

- Remove the seals venting plugs (Label ST in paragraph 4.4) and clean them with a solvent.
- Do not use compressed air and/or solvents in the seals venting ducts in the pump benches. Internal seals can be damaged.

**Attention: do not use compressed air and/or solvents in the seals venting ducts in the pump benches. Internal seals can be damaged.**

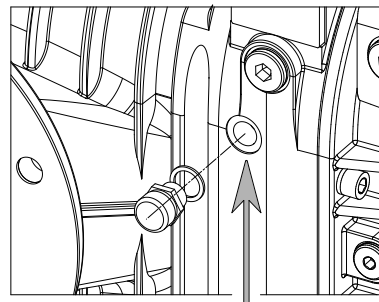

Pic. 6.3

**Every 10.000 working hours: general overhauling**

- In case of particularly hard formations, general overhaul of the pump is recommended: rotors wash-up, seals check, replacement of bearing and sealing ring, and lubricant replacement. The servicing operations which require the pump to be completely disassembled must be performed at a Service Centre authorised by JUROP.

**The servicing operations which require the pump to be completely disassembled must be performed at a Service Centre authorised by JUROP.**

## 7. Malfunctions: troubleshooting

### PROBLEMS

#### Reduced performances

Cause	Solution
• Speed not correct	• Check and restore
• Pipes and/or filters clogged or leaking	• Check conditions and restore
• Pipes are undersized	• Check the maximum compressor performance
• Safety valves not adjusted	• Check and adjust correctly

#### Overheating

Cause	Solution
• Ambient and/or suction or injected air temperature is too high.	• Reduce pressure or vacuum rate
• Inefficient air injection	• Check that the suction port of the air injection silencer is clean, check condition of the injection line and clapet valve.
• Pipes are undersized	• Check, close to the pump ports, the effective suction and delivery pressure. Do not exceed operating limits.

#### Oil leakage

Cause	Solution
• Front sealing ring is worn	• Replace it
• Level indicators broken	• Replace it
• Oil leakage from internal seals	• Check the pump inclination (max. 3°). Service to check the linternal seals. • If this is not enough to solve the problem, contact the after sale.

#### Abnormal vibrations or noise (stop the vacuum pump)

Cause	Solution
• The rotors are getting in contact	• Temperature is over the max working limits ( $T_2 > 160^\circ\text{C}$ and/or $T_2 - T_1 > 130^\circ\text{C}$ : see par. 2.6). Stop the pump and leave it cooling. Start again only after the alarm has reset.
• Rotors with hard formations on the surface	• Inner wash of the pump. • Remove the in/out pipes and clean rotors and housing.
• Suction of liquids or foreign bodies	• If they have caused incrustations, the pipes must be removed and the rotors must be cleaned.
• Not uniform power transmission	• Check the operating conditions. Do not install propellers too much angled.

## 8. Scrapping

• Recycling materials allow reducing the environmental impact and respecting the environment.



**Do not dispose of in the environment. Dispose of in compliance with the standards in force.**

• Before scrapping the machine, the following materials need to be separated and suitably disposed of:

Materiale	Cast Iron	Steel	Alluminum	Bronze	Rubber	Gasket	Oil
PVT 200	79 %	13 %	6.8 %	0.0 %	0.1 %	0.1 %	0.6 %
PVT 280	74 %	17 %	7.8 %	0.3 %	0.1 %	0.1 %	1.1 %
PVT 400	70 %	22 %	7.1 %	0.2 %	0.1 %	0.1 %	0.9 %
PVT 700	78 %	14 %	6.9 %	0.2 %	0.0 %	0.0 %	0.5 %
PVT 1000	74 %	19 %	6.1 %	0.2 %	0.0 %	0.0 %	0.4 %

## 9. Accessories

### 9.1 Silencers: models and dimensions

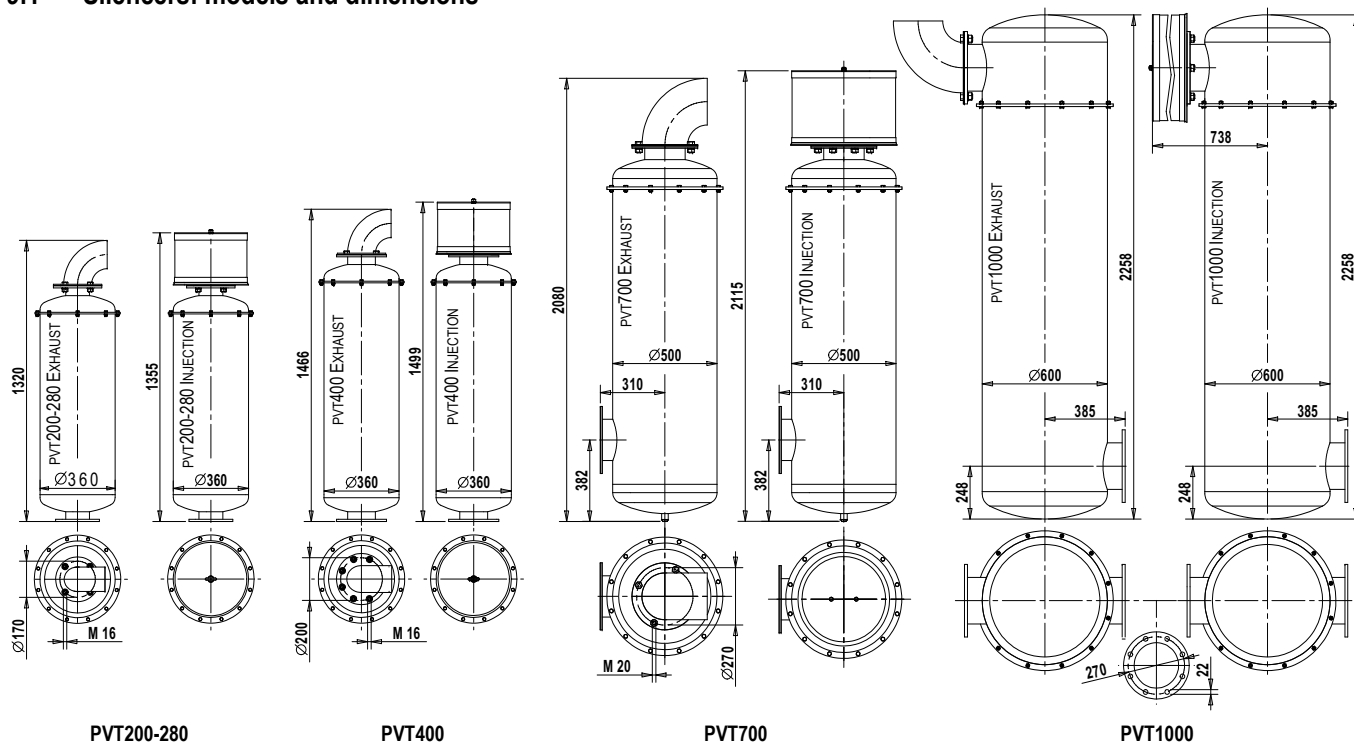

MODEL	PVT 200-280		PVT 400		PVT 700		PVT 1000	
TYPE	EXHAUST	INJECTION	EXHAUST	INJECTION	EXHAUST	INJECTION	EXHAUST	INJECTION
FLANGE *	DN100 PN6	DN100 PN6	DN125 PN6	DN125 PN6	DN175 PN10	DN175 PN10	DN175 PN10	DN175 PN10
IRON VERSION	1414014600	1414014700	1414014200	1414014300	1414013800	1414013900	1414014000	1414014100
INOX VERSION	1414014800	1414014900	1414014400	1414014500	-	-	-	-
WEIGHT	46 kg	57 kg	52 kg	64 kg	108 kg	135 kg	193 kg	220 kg

\* UNI 2277-67

### 9.2 Accessories PVT200 - 280 - 400

#### Dimensions PVT200

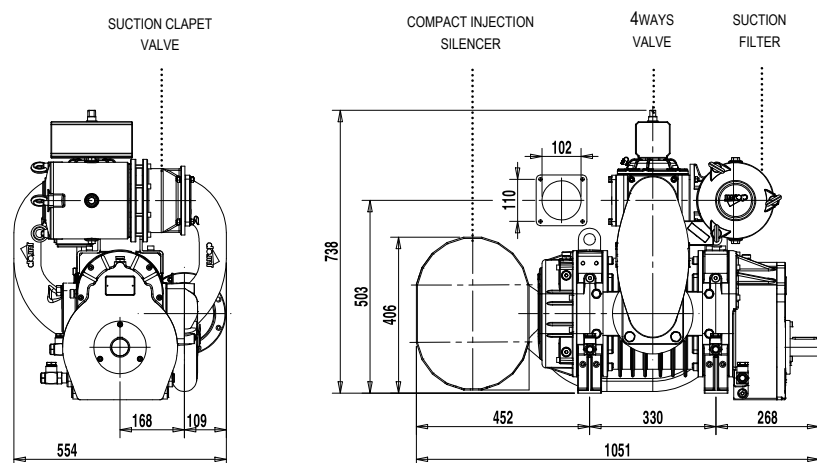

Code	Description	kg
1847000300	Compact injection silencer	29,5
1852112000	Suction group with pneumatics 4ways valve and filter	59

### Dimensions PVT280

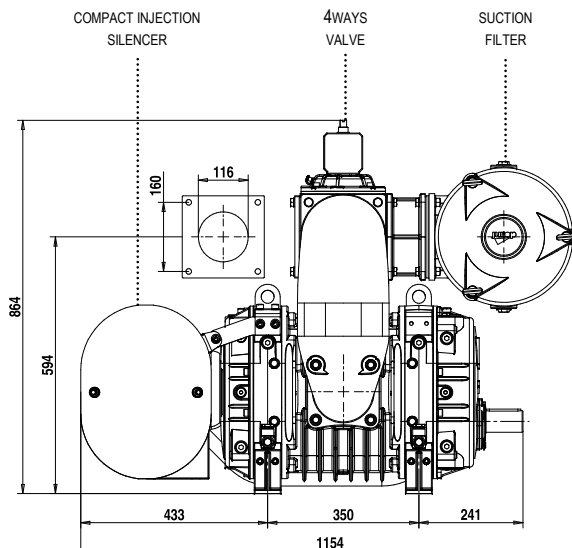
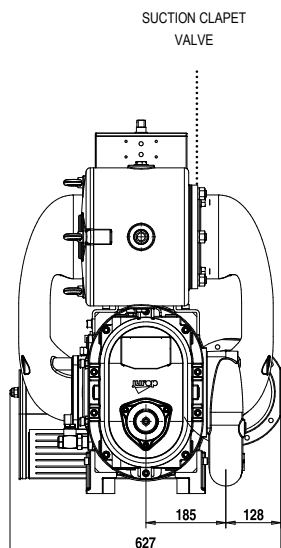

Code	Description	kg
1847000400	Compact injection silencer PVT280	29,5
18521001E0	Suction group with Pneumatic 4 ways valve and filter PVT280	71
1847000400	Compact injection silencer PVT400	29,5
1852108200	Suction group with Pneumatic 4 ways valve and filter PVT400	108

### Dimensioni PVT400

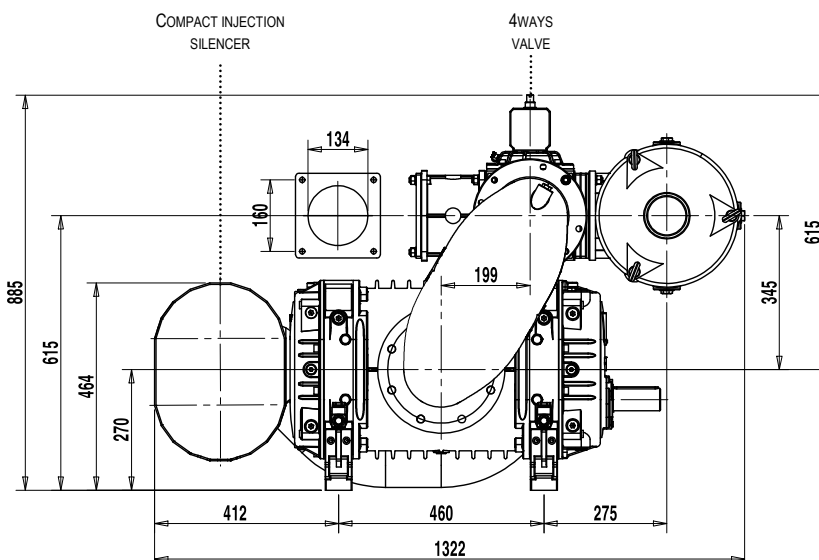
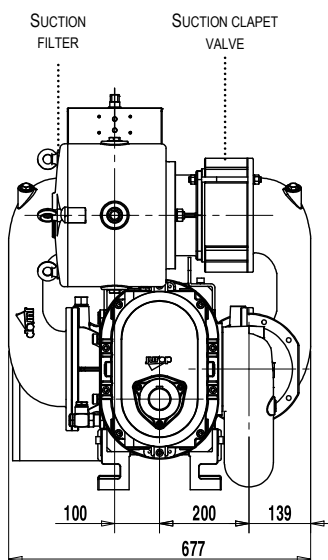

### Characteristics

- Pre-assembled group installed to the vacuum pump and complete with:
  - Aluminium and cast iron manifolds
  - 4ways valve
  - Clapet (non return) valve
  - Suction filter
- This suction group can be installed on all the PVT200-400 with horizontal ports (read paragraph 2.2).
- The compact injection silencer replace the standard injection silencer. It is installed on the PVT side and it is made of galvanized S235JR.

### Operating limits

- The suction group is developed to make the installation easier on stationary or mobile vacuum-pressure plants, conveying air. If other gases have to be conveyed, check first the compatibility with the vacuum pump.



**Attention: If other gases have to be conveyed, check first the compatibility with the vacuum pump.**

- The flow losses caused by the components on the vacuum line can reduce the nominal air flow of the pump.
- The presence of a 4-way valve can be cause of the working temperature increase on the pump, especially during a continuous duty.

### Installation

- Compulsory accessories:
  - Exhaust silencer.
  - Injection silencer: use only the specific silencer of the PVT.
  - Overheating alarm to be connected to the thermostat on the exhaust port (which is always included on the standard pump execution).

- Secondary shutoff on the vacuum line to grant a good protection of the pump against the accidental suction of liquids and solid bodies.
- Suitable safety overpressure valves.
- Check on the first part of this manual for all the indications about the technical data, safety, installation, use and maintenance of the PVT.
- Provide for the necessary space to reach the manual 4-way valve to operate it. In the case of pneumatic valve, refer to the note “Pneumatic actuator adjustment”.

**Suction group maintenance**

- **4-way valve cock adjusting.** When the valve cock is hard to move, we recommend to adjust its clearance with the housing. This can be done through the screw placed under the valve itself.
- **Suction filter cleaning.** remove the filter cover to access to the filtering cartridge. Clean it and, if necessary, clean also the filter housing. Refer to the dedicated technical sheet.

- **Clapet (non return) valve.** Periodic checks to avoid the accidental suction of solid bodies:
  - Every year: replace the OR.
  - Every 3 years: replace the clapet and related screw/bolts.
- When reassembling, rotate the clapet as indicated in the figure above: the valve must allow air flow sucked into the pump and not coming out from the pump.
- Angle the clapet pivoting axle of 30 deg from the horizontal.

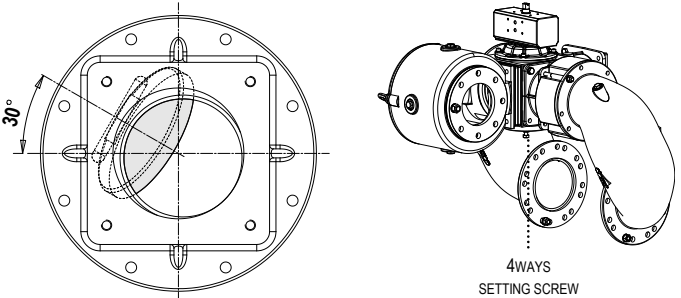

**9.3 Accessories PVT700**

**Dimensions PVT700**

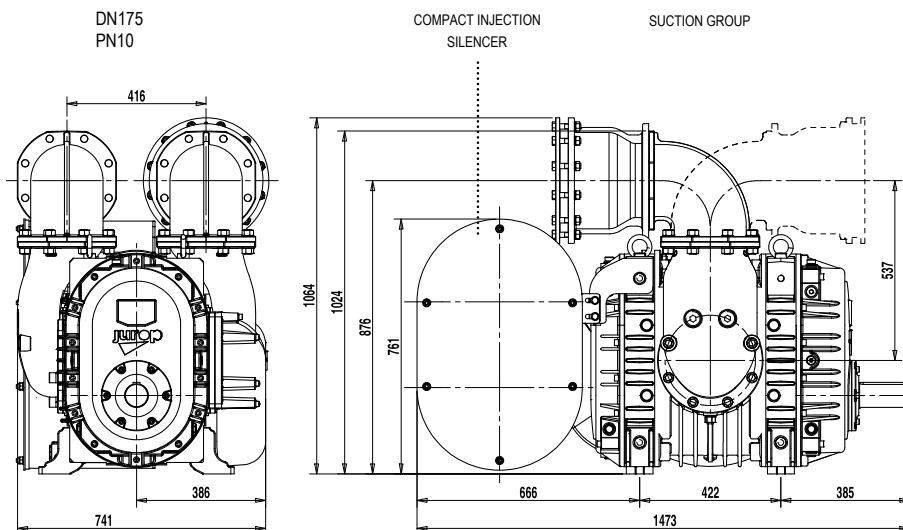

Code	Description	
1414013700	Compact injection silencer	82
1852109100	Manifolds group	
18521021E0	Suction Group	140

**Charateristics**

- The manifolds group is directly mounted on the pump ports and it is developed to reduce the plant dimensions. It is composed of:
  - 2 aluminum manifolds and 2 cast iron manifolds
  - Clapet (non return) valve with relative aluminum manifold.

The manifolds group do not include the 4 ways valve and the suction filter.

**Attention: The manifolds group do not include the 4 ways valve and the suction filter.**

- It is possible to install the manifold group in all the PVT700 excepts for the arrangements PVT700SX-O-B and PVT700DX-O-A (Read paragraph 2.1).

- The compact injection silencer replace the standard injection silencer. It is installed on the PVT side and it is made of galvanized S235JR.

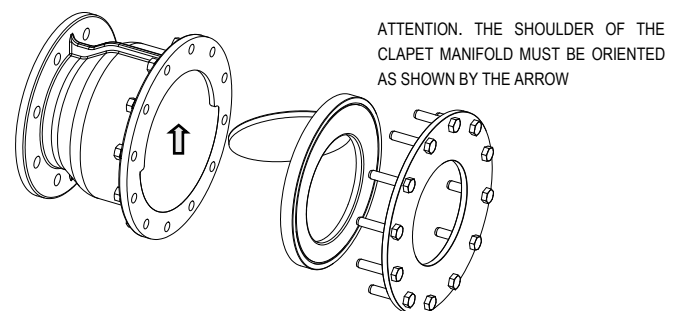

• The suction filter (1445006300) is made of galvanized S235JR and is provided with an internal stainless steel cartridge. Avoid to place the out-port (PVTside) of the filter facing the ground when positioning

the filter. This could be dangerous during the filter cleaning because some solid parts could enter in the pump suction port.

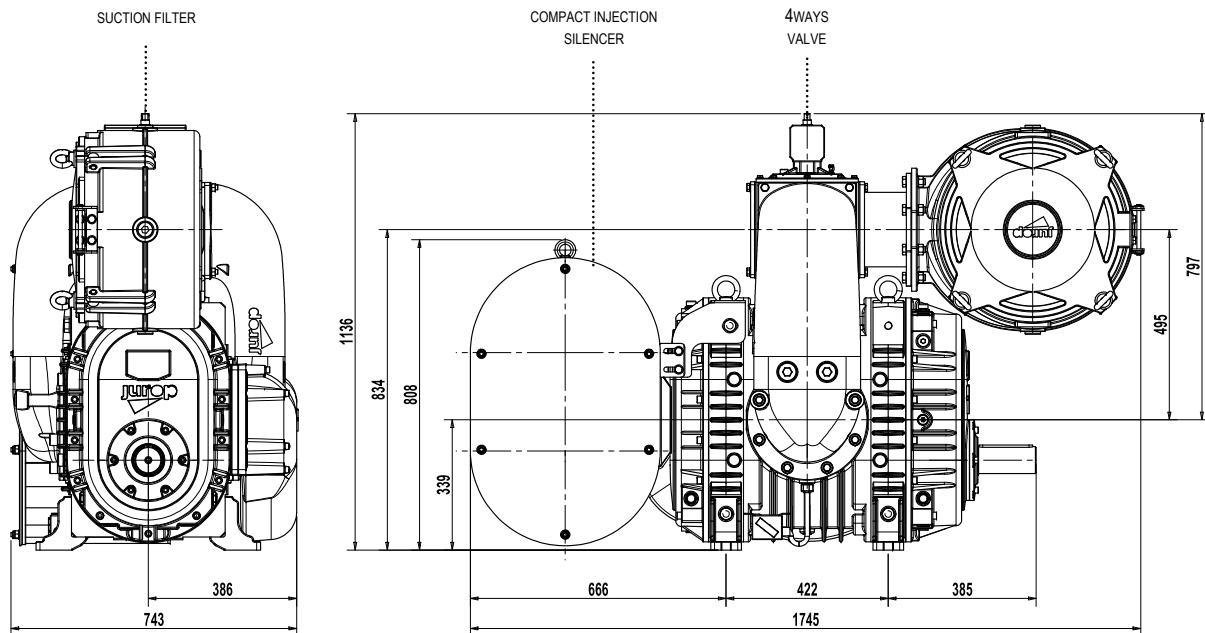

**Characteristics**

- Pre-assembled group installed to the vacuum pump and complete with:
  - Aluminium and cast iron manifolds
  - 4ways valve
  - Clapet (non returne) valve
  - Suction filter
- This suction group can be installed on all the PVT with horizontal ports (read paragraph 2.1).
- The compact injection silencer replace the standard injection silencer. It is installed on the pump side and it is made of galvanized S235JR.

**Operating limits**

- Accessories are developed to make the installation easier on stationary or mobile vacuum-pressure plants, conveying air.
  - If other gases have to be conveyed, check first the compatibility with the vacuum pump.
  - The flow losses caused by the components on the vacuum line can reduce the nominal air flow of the pump.

**Attention: the flow losses caused by the components on the vacuum line can reduce the nominal air flow of the pump.**

**Installation**

- Compulsory accessories:
  - Exhaust silencer.
  - Injection silencer.

- Overheating alarm to be connected to the thermostat on the exhaust port (which is always included on the standard pump execution).
- Secondary shutoff on the vacuum line to grant a good protection of the pump against the accidental suction of liquids and solid bodies.
- Suitable safety overpressure valves.
- Check on the first part of this manual for all the indications about the technical data, safety, installation, use and maintenance of the PVT.
- Provide for the necessary space to reach the manual 4-way valve to operate it. In the case of pneumatic valve, refer to the note "Pneumatic actuator adjustment".

**Clapet valve maintenance**

- Periodic checks to avoid the acidental suction of solid bodies:
  - Every year: replace the OR.
  - Every 3 years: replace the clapet and related screw/bolts.
- When reassembling, rotate the clapet as indicated in the figure above: the valve must allow air flow sucked into the pump and not coming out from the pump.
- Angle the clapet pivoting axle of 30 deg from the horizontal.

**Suction group maintenance**

- **4-way valve cock adjusting.** When the valve cock is hard to move, we recommend to adjust its clearance with the housing. This can be done through the screw placed under the valve itself.
- **Suction filter cleaning.** Remove the filter cover to access to the filtering cartridge. Refer to the dedicated technical sheet.
- Clean it and, if necessary, clean also the filter housing.

- **Clapet (non return) valve.** Periodic checks to avoid the accidental suction of solid bodies:
  - Every year: replace the OR.
  - Every 3 years: replace the clapet and related screw/bolts.
- When reassembling, rotate the clapet as indicated in the figure above: the valve must allow air flow sucked into the pump and not coming out from the pump.
- Angle the clapet pivoting axle of 30 deg from the horizontal.

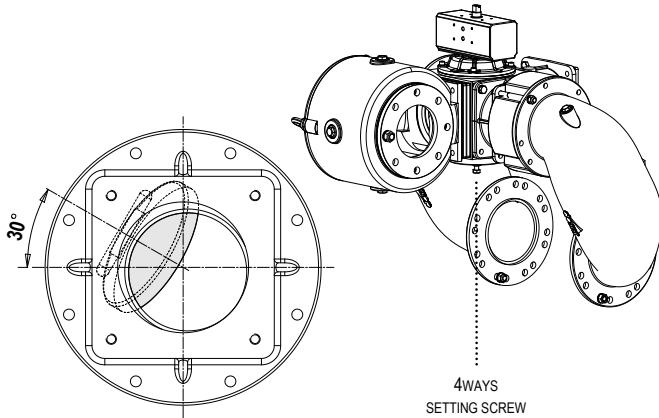

### Inverter pneumatic actuator

- In the event of 4-way valves equipped with pneumatic actuator, we recommend installing two one-way flow regulators between the pneumatic “control” and the pneumatic actuator. The following figure shows a schematic view of a possible pneumatic installation.

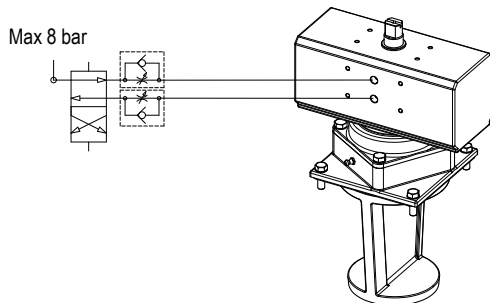

- We recommend adjusting the two flow regulators in order for rotation to occur without knocks and with a switching time of at least one second.
- In case of interruption of the pneumatic supply, the inverter of the suction unit remains in the same position it was when the failure occurred

PVT 200

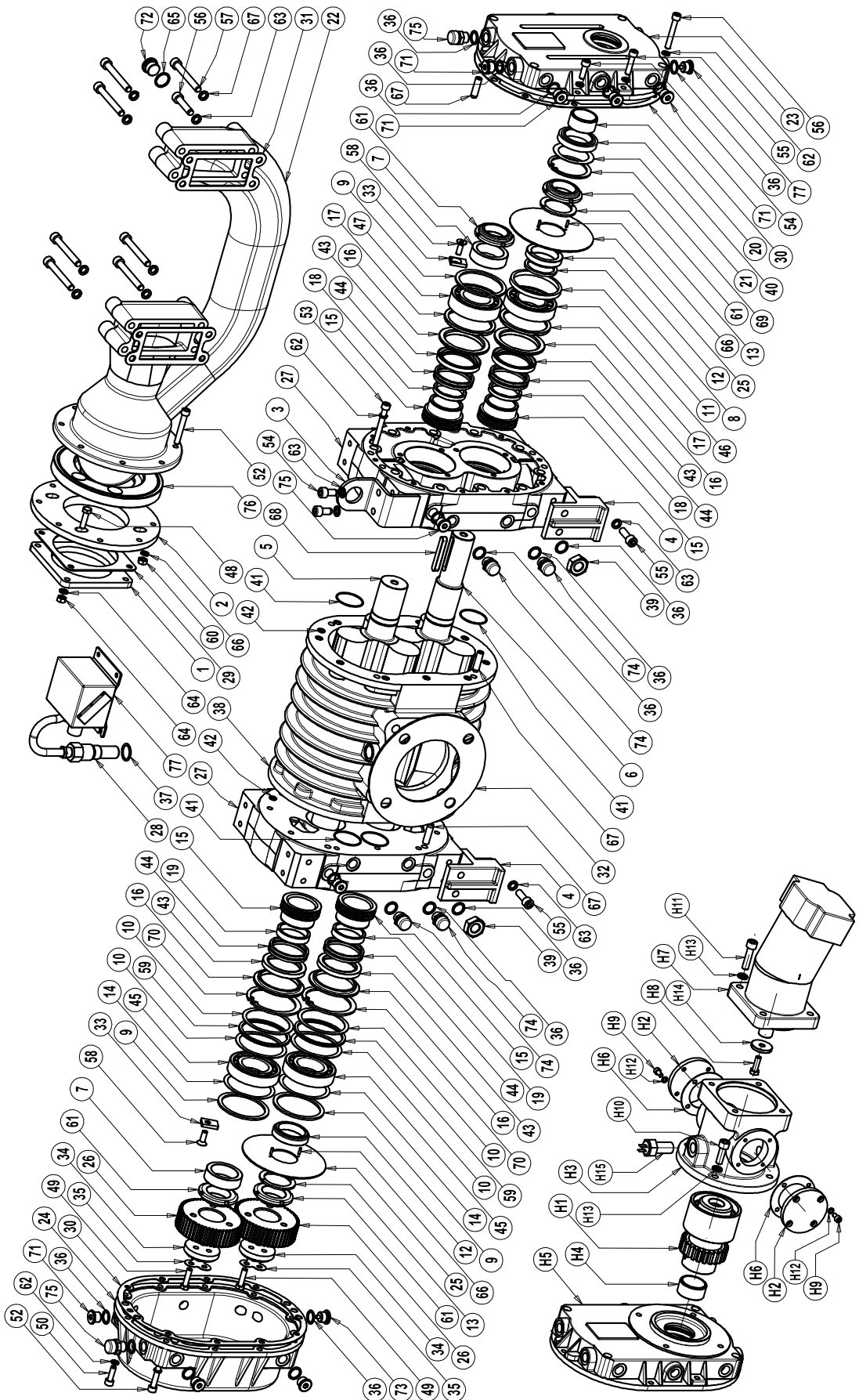



**PVT 200**

Pos.	Code	Description	Q.ty	Pos.	Code	Description	Q.ty
1	16100BDSB0	FLANGE	1	41	4022200313	OR 2162	4
2	1610513800	FLANGE	1	42	4022200317	OR 108	20
3	1613034900	SUPPORT	2	43	4022202806	Y-SEAL	4
4	1613501300	SUPPORT	4	44	4022203601	PTFE RING	8
5	1621506100	DRIVED LOBE	1	45	4023115046	BEARING NUP 209 ECJ/C3	2
6	1621506200	DRIVING LOBE	1	46	4023115051	BEARING NJ 209 ECJ/C3	1
7	1624035500	SPACER 60X45X18	2	47	4023115053	BEARING NJ 2209 ECJ/C4	1
8	1624035600	SPACER 54X45X4	1	48	4026102808	SCREW M8X30	4
9	1624035700	SPACER 85X73X3	3	49	4026107111	SCREW M8X30	6
10	1624036000	SPACER	4	50	1624501500	SCREW M8X25	10
11	1624036100	SPACER 87X76X7	1	51	1647000100	SCREW M8X35	2
12	1624036200	SPACER	2	52	1624027800	SCREW M8X55	17
13	1624036300	SPACER	2	53	1624028500	SCREW M8X70	20
14	1624036900	ADJUSTING SPACER	2	54	1624027700	SCREW M10X20	4
15	1624040300	SEAL BUSHING	4	55	4023105007	SCREW M10X30	8
16	1624040700	SPACER	4	56	1681007800	SCREW M10X45	1
17	1624040800	SPACER	2	57	4026306309	SCREW M10X80	7
18	1624040900	SPACER	2	58	4026107110	SCREW M8X18	12
19	1624041000	SPACER	2	59	4026300018	FEDER RING	8
20	162404TQB0	BUSHING	1	60	4026308005	BOLT M8	12
21	162404TUB0	SPACER	1	61	402630RB05	RING NUT M45X1.5 SELF LOCKING	4
22	1627104700	INJECTION MANIFOLD	1	62	4026350505	WASHER GROWER M8 SQUARE	48
23	1640102100	FRONT COVER	1	63	4026350506	WASHER GROWER M10 SQUARE	20
24	1640102200	REAR COVER	1	64	4026350706	WASHER GROWER M8 FLAT	4
25	1647001200	OIL DISC	2	65	4026359003	WASHER 21.5X26X1.5 AL.	1
26	1651002RA0	TIMING GEAR	2	66	4026401101	PIN 3X12	4
27	1662500800	BENCH	2	67	4026401806	PIN 10X36	12
28	16630A1XB0	THERMOSTAT HOUSING	1	68	4026500911	TAB 10X8X63	1
29	1680609100	GASKET	1	69	4026510538	SEEGER I 68	1
30	1680709600	GASKET	2	70	4026510545	SEEGER I 85	2
31	1680711600	GASKET	2	71	4026701602	PLUG 3/8	16
32	1680712000	GASKET	2	72	4026701603	PLUG 1/2	1
33	1681008400	BEARING PLATE	12	73	4026701620	MAGNETIC PLUG 3/8	2
34	1681008500	WASHER	2	74	4026910006	VENTIL PLUG 3/8	4
35	1681008600	WASHER	2	75	4026910102	VENTIL PLUG 3/8 WITH VALVE	2
36	1685100200	WASHER	26	76	4027400413	CLAPET VALVE DN125 PN6	1
37	16851ABUB0	WASHER	1	77	4028249B00	THERMOSTAT	1
38	1687508900	HOUSING	1				
39	4022104501	PLUG 3/8	1				
40	4022200154	ANELLO TENUTA	1	1892007600	GASKET KIT PVT200 IL		1

**PVT 200 - HDR**

Pos.	Code	Description	Q.ty	Pos.	Code	Description	Q.ty
H1	14701004E0	JOINT	1	H8	4026102807	SCREW M8X25	1
H2	1610051700	FLANGE	2	H9	4026120301	SCREW M6X12	8
H3	1612504500	HDR MOTOR MOUNTING FLANGE	1	H10	4026120506	SCREW M10X30	4
H4	162404TQB0	BUSHING	1	H11	4026120508	SCREW M10X40	4
H5	1640501500	FRONT COVER HDR	1	H12	4026350503	WASHER GROWER M6 SQUARE	8
H6	1680709700	GASKET	2	H13	4026350506	WASHER GROWER M10 SQUARE	8
H7	402416DC02	HYDRAULIC MOTOR	1	H14	4026353800	WASHER 35X8.5	1
	402416DC50	FLUSHING VALVE (OPTIONAL)	1	H15	4028321601	REV. COUNTER SENSOR	1

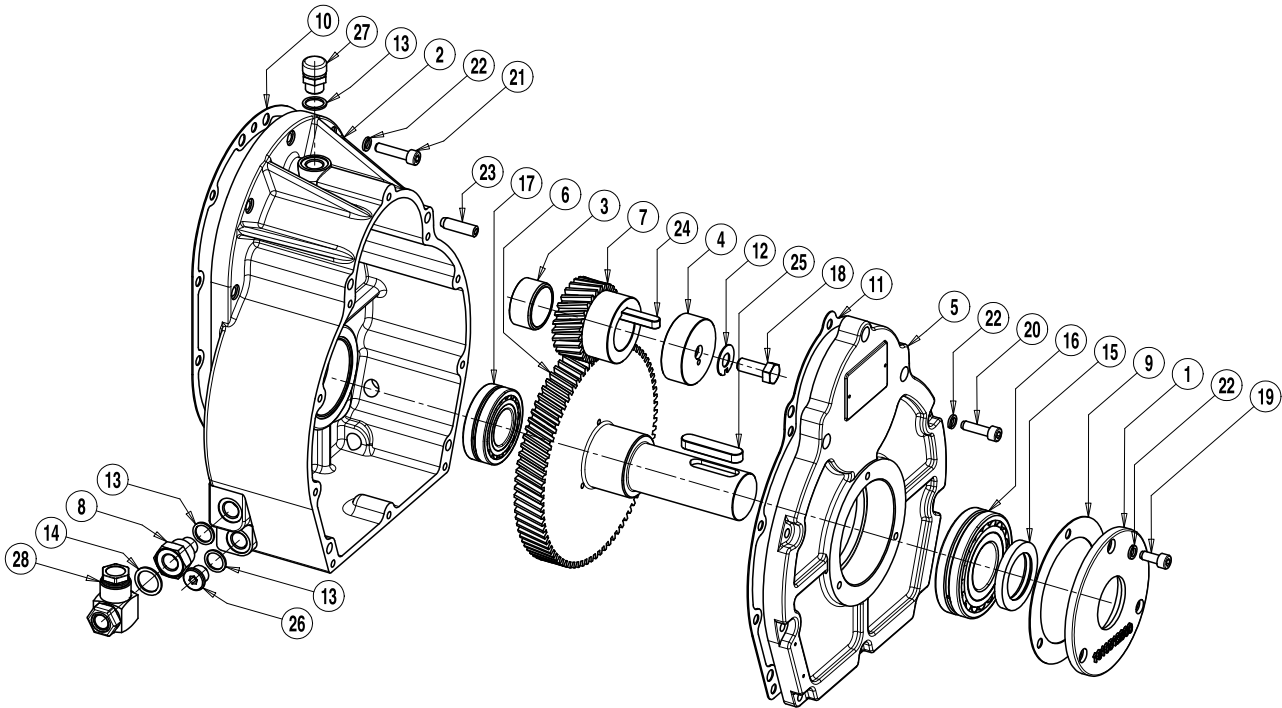
**PVT 200 MULTIPLIER**

**PVT 200 Multiplier**

Pos	Code	Description	Q.ty	Pos	Code	Description	Q.ty
1	1610512300	FLANGE	1	15	4022200412	Y-SEAL	1
2	161058B2B0	FRONT FLANGE	1	16	4023105008	BEARING 21309 E/C3	1
3	162404TQB0	BUSHING	1	17	4023105009	BEARING 22207 E/C3	1
4	1624082EB0	SPACER	1	18	4026107311	SCREW M12X30	1
5	164058B8B0	FRONT COVER	1	19	4026120403	SCREW M8X20	3
6	165107ZZB0	DRIVING GEAR	1	20	4026120406	SCREW M8X30	10
7	16510802B0	DRIVED GEAR	1	21	4026120407	SCREW M8X35	10
8	16730937B0	CONNECTION	1	22	4026350505	WASHER GROWER M8	23
9	1680708700	GASKET	1	23	4026401806	PIN 10X36	8
10	1680709600	GASKET	1	24	4026500911	TAB 10X8X63	1
11	1680795CB0	GASKET	1	25	4026501605	TAB 14X9X63	1
12	1685002400	SAFETY WASHER	1	26	4026701620	MAGNETIC PLUG 3/8	1
13	1685100200	WASHER 17X22X1.5 AL	3	27	4026910102	PLUG 3/8	1
14	16851DBVB0	WASHER 21.5X28X1.5 CU	1	28	40269KPB00	OIL LEVEL	1

**PVT 280 - 400 HDR**

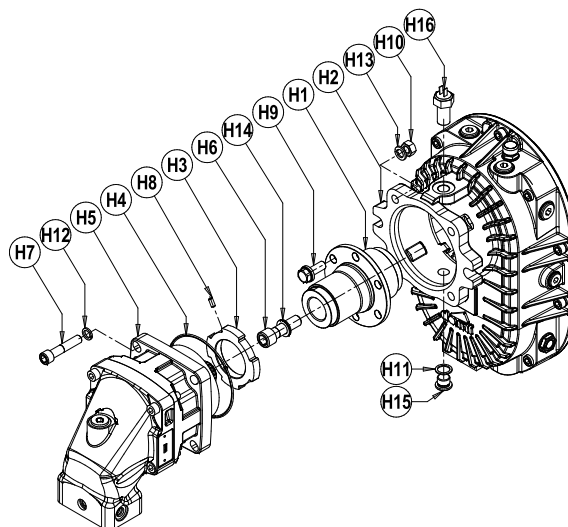
**PVT 280 - 400 - HDR**



**PVT 280 - 400 - HDR**

Pos.	Code	Description	Q.ty	Pos.	Code	Description	Q.ty
H1	16110010E0	HELIX450 HDR JOINT	1	H9	40261D2C10	SCREW TE FLANG M12X30	6
H2	16401129E0	HELIX450 HDR FRONT COVER	1	H10	4026308007	NUT M12 ESAG. ZINC.	4
H3	16510027E0	HELIX300-450 GEAR	1	H11	4026312B06	WASHER IN RAME DA 18	1
H4	4022200383	OR 4487	1	H12	4026350508	WASHER GROWER 12 ZINC.	4
H5	4024107540	PVT280 HDR MOTOR	1	H13	4026350709	WASHER GROWER 12 ZINC.	4
	4024107541	PVT400 HDR MOTOR	1	H14	4026385C25	WASHER M16 ZINC.	3
H6	4026121214	SCREW TCEI M16X55 ZINC.	1	H15	4026701670	PLUG M C/TESTA M18X1,5	1
H7	4026121715	SCREW TCEI 8,8 M 12 X 60 ZINC.	4	H16	4028321601	ELECTRIC SENSOR	1
H8	4026136205	SCREW M6X12	2				

PVT 280 - 400

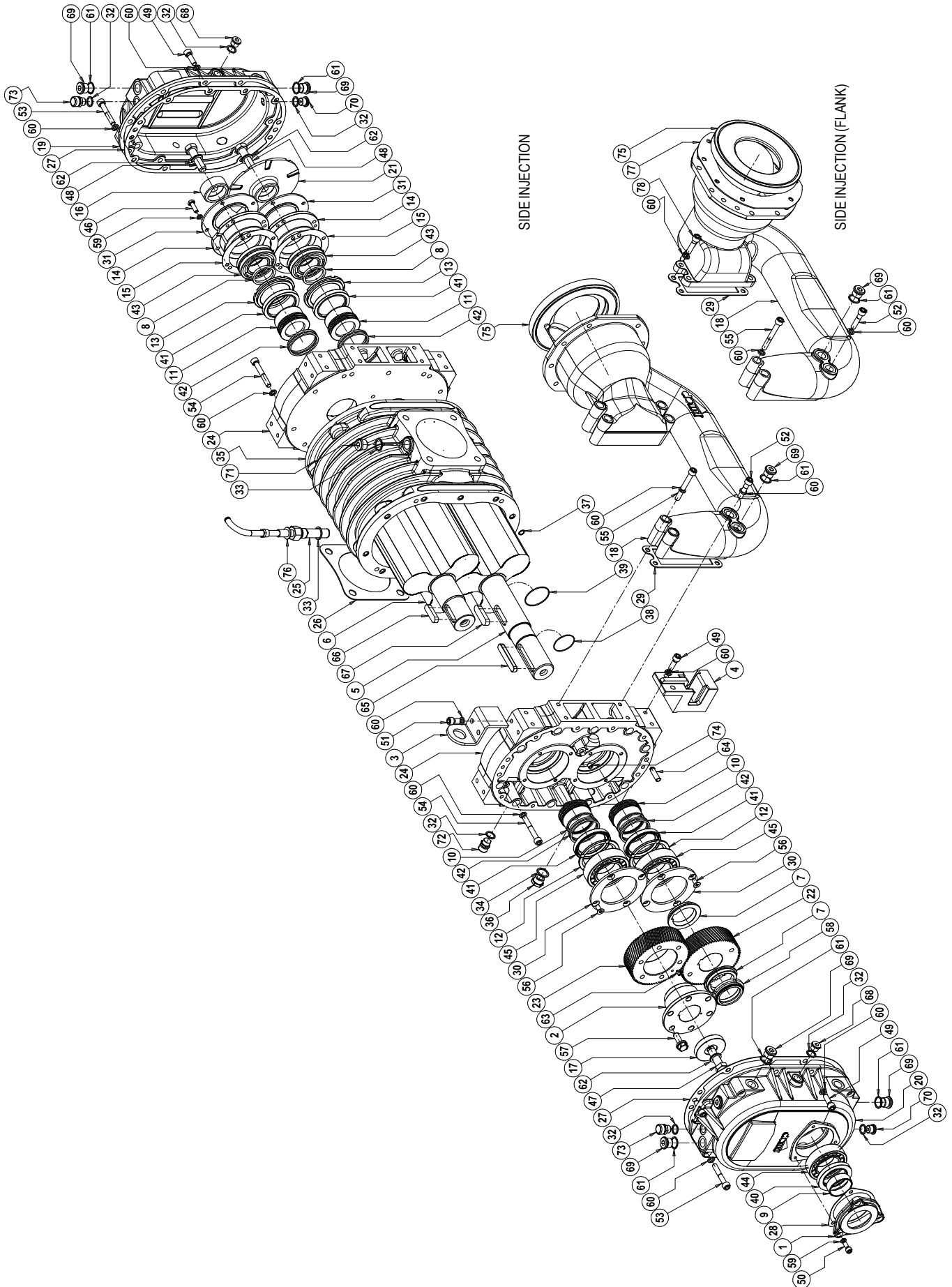

**PVT 280 - 400**

Pos.	Code	Description	Q.ty	Pos.	Codice	Descrizione	Q.tà
1	1610512200	SHAFT FLANGE	1	50	4026121405	SCREW TCEI M8X20 ZINC.	3
2	1611000900	ADJUSTING HUB	1	51	4026121807	SCREW TCEI M10X20 ZINC.	4
3	1613034900	SUPPORT	2	52	4026121812	SCREW TCEI M10X45 ZINC.	2
4	1613501300	SUPPORT PVT280	4		4026121815	SCREW TCEI M10X60 ZINC.	1
	1613501200	SUPPORT PVT400		53	4026121815	SCREW TCEI M10X60 ZINC.	8
5	16215003E0	DRIVING LOBE PVT280	1	54	4026121816	SCREW TCEI M10X70 ZINC.	20
	15215014E0	DRIVING LOBE PVT400	1	55	4026121817	SCREW TCEI M10X80 ZINC. (PVT280)	6
6	16215004E0	DRIVED LOBE PVT280	1		4026121819	SCREW TCEI M10X100 ZINC. (PVT400)	7
	15215015E0	DRIVED LOBE PVT400	1	56	4026155706	SCREW TSPEI M8X18 ZINC.	8
7	1624027600	SPACER	2	57	40261D2C10	SCREW TE M12X30	6
8	1624027800	SPACER	2	58	402630RB07	RING NUT M55X2 SELF LOCKING	1
9	1624030200	USHING 50X55X18	1	59	4026350505	WASHER GROWER 8 ZINC.	11
10	1624040100	FRONT SEAL BUSHING	2	60	4026350506	WASHER GROWER 10 ZINC.	60
11	1624040200	REAR SEAL BUSHING	2	61	4026359003	WASHER 21,5X26X1,5	16
12	1624040400	FRONT SEAL SPACER	2	62	4026385C25	WASHER M16 ZINC.	3
13	1624040500	REAR SEAL SPACER	2	63	4026401101	PIN 3X12	1
14	1624041200	BEARING BUSHING	2	64	4026401806	PIN 10X36	8
15	1624041300	ADJUST. SPACER THICKNESS 0.5	2	65	4026501607	TAB 14X9X80	1
16	16260020E0	REAR SPIGOT	1		4026501609	TAB 14X9X100	1
17	16260021E0	FRONT SPIGOT	1	66	4026502003	TAB 14X9X50	1
18	16271001E0	INJECTION MANIFOLD PVT280	1	67	4026502106	TAB 16X10X56	1
	16271005E0	INJECTION MANIFOLD (SIDE INJ. FLANK)	1	68	4026701602	PLUG 3/8 FE ZINC.	6
	1627104600	INJECTION MANIFOLD PVT400	1	69	4026701603	PLUG 1/2 FE ZINC.	16
	1627105600	INJECTION MANIFOLD (SIDE INJ. FLANK)	1	70	4026701620	MAGNETIC PLUG G3/8	2
19	1640102000	REAR COVER	1	71	4026904510	PLUG M22X1,5 (PVT280)	1
20	1640500800	FRONT COVER	1	72	4026910006	VENTIL PLUG 3/8	4
21	16471001E0	OIL DISC	1	73	4026910102	VENTIL PLUG	2
22	1651008800	TIMING GEAR	1	74	4026910601	PLUG 1/8'	4
23	1651008900	ADJUSTING TIMING GEAR	1	75	4027400414	CLAPET VALVE DN150 PN6 ZINC.	1
24	1662500700	BENCH	2	76	4028249B00	THERMOSTAT	1
25	166308WRB0	THERMOSTAT HOUSING PVT280	1	77	1612088IB0	PLATE FOR CLAPET (SIDE INJ. FLANK)	1
	16630ZUPA0	THERMOSTAT HOUSING PVT400	1	78	4026121811	SCREW M10X40 (SIDE INJ. FLANK PVT280)	4
26	16807001E0	GASKET PVT280	2		4026121811	SCREW M10X40 (SIDE INJ. FLANK PVT400)	3
	1680613800	GASKET PVT400	2		4026121812	SCREW M10X45 (SIDE INJ. FLANK PVT400)	1
27	1680708200	GASKET	2				
28	1680708400	GASKET	1		1892009500	GASKET KIT PVT280	
29	1680711500	GASKET	2		1892007700	GASKET KIT PVT400	1
30	1681009100	BEARING FLANGE	2				
31	1681009200	BEARING FLANGE	2				
32	1685100200	WASHER 17X22X1.5 AL	14				
33	16851ABUB0	WASHER 28X22.5X1.5 CU	2				
34	16851DBVB0	WASHER 21.5X28X1.5 CU	2				
35	16875002E0	HOUSING PVT280	1				
	1687509000	HOUSING PVT400	1				
36	4022104502	PLUG 1/2	2				
37	4022200318	OR 2043	20				
38	4022200322	OR 2175	3				
39	4022200374	OR 2212	2				
40	4022200425	Y-SEAL 80X55X10	1				
41	4022202805	Y-SEAL BABSL 85X65X10	4				
42	4022203600	PTFE RING 70X63X3.8	8				
43	4023105007	BEARING 22209 E/C3	2				
44	4023110060	BEARING NU 2210 ECJ/C3	1				
45	4023110065	BEARING NU 2211 ECJ/C3	2				
46	4026102807	SCREW TE M8X25 ZINC.	8				
47	4026103212	SCREW TE M16X50 ZINC.	1				
48	4026103214	SCREW TE M16X60 ZINC.	2				
49	4026120506	SCREW TCEI M10X30 ZINC.	20				

PVT 700 - 1000

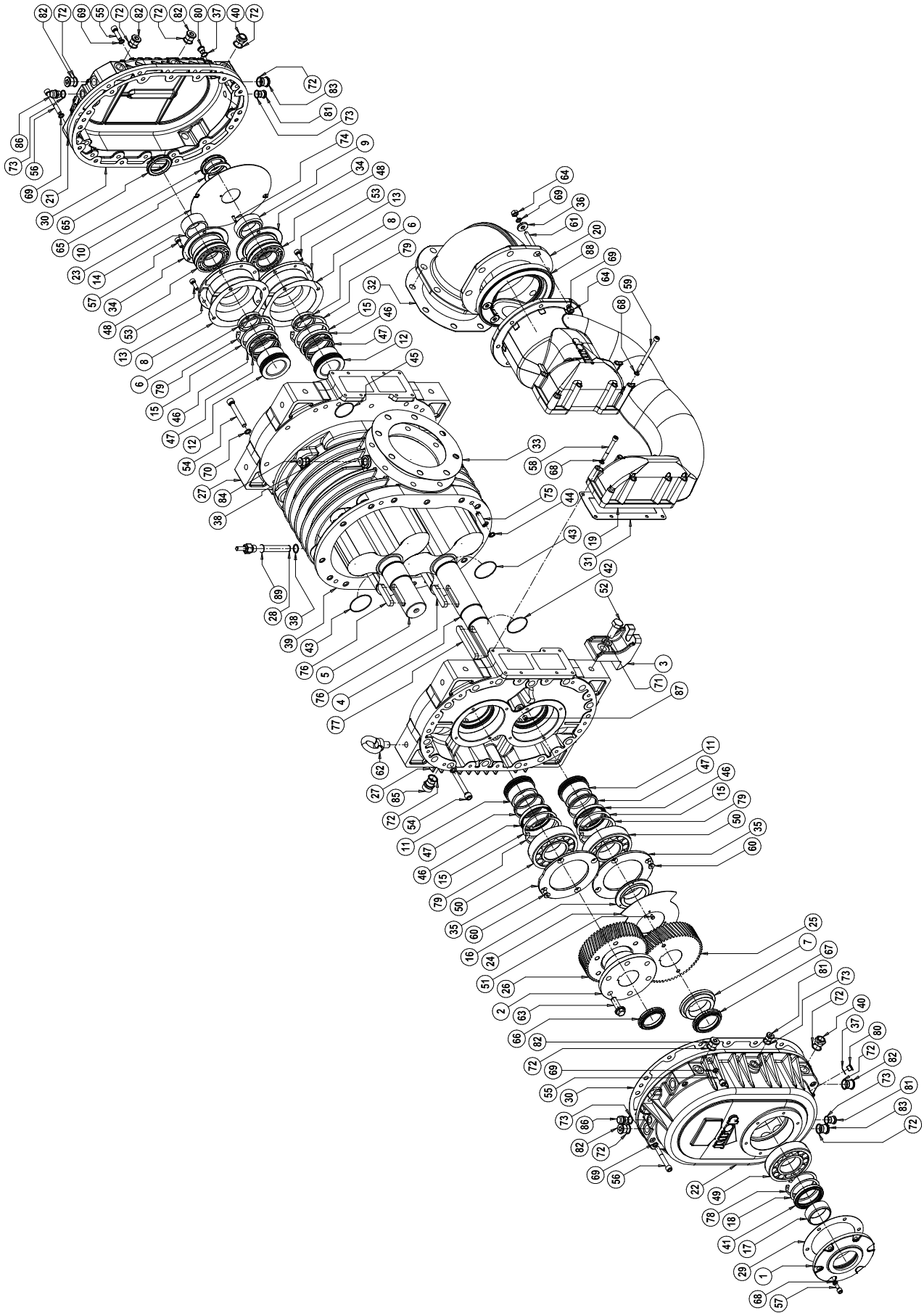

**PVT 700 - 1000**

Pos.	Code	Description	Q.ty	Pos.	Code	Description	Q.ty
1	1610513700	SHAFT FLANGE	1	54	4026120719	SCREW M14X100	28
2	161104EAB0	ADJUSTING HUB	1	55	4026121711	SCREW M12X40	20
3	1613501700	SUPPORT	4	56	4026121720	SCREW M12X90	9
4	1621508300	DRIVING LOBE PVT700	1	57	4026121808	SCREW M10X25	12
	1521506200	DRIVING LOBE PVT1000	1	58	4026121818	SCREW M10X90	4
5	1621508400	DRIVED LOBE PVT700	1	59	4026121823	SCREW M10X140	11
	1521506100	DRIVED LOBE PVT700	1	60	4026155807	SCREW M10X20	8
6	1624038800	SPACER	2	61	4026171211	SCREW M12X80	8
7	1624038900	SPACER	1	62	4026190103	EYE BOLT M20	2
8	1624039000	ADJUST. SPACER THICKNESS 0.5	CK	63	40261D3C10	SCREW M16X50	6
	1624039100	ADJUST. SPACER THICKNESS 0.1	CK	64	4026308007	BOLT M12	16
9	1624039300	SPACER	1	65	402630RB09	RING NUT WASHER MB13 M65X2	2
10	1624039400	SPACER	1	66	402630RB10	RING NUT WASHER MB14 M70X2	1
11	1624041500	FRONT SEAL BUSHING	2	67	402630RB11	RING NUT WASHER MB15 M75X2	1
12	1624041600	REAR SEAL BUSHING	2	68	4026350506	WASHER GROWER M10 SQUARE	21
13	1624041700	BEARING BUSHING	2	69	4026350508	WASHER GROWER M12 SQUARE	44
14	1624041800	SPACER	1	70	4026350509	WASHER GROWER M14 SQUARE	28
15	1624041900	SPACER	4	71	4026350713	WASHER GROWER M20 FLAT	4
16	1624042000	SPACER	1	72	4026359000	WASHER 32X26X1.5 AL	17
17	162404TSB0	BUSHING	1	73	4026359003	WASHER 21.5X26X1.5 AL	7
18	162404TWB0	SPACER	1	74	4026401208	PIN 6X24	1
19	1627104800	INJECTION MANIFOLD	1	75	4026402011	PIN 14X55 M8	12
20	1627104900	90° MANIFOLD DN175	1	76	4026501404	TAB 20X12X90	2
21	1640102600	REAR COVER	1	77	4026501408	TAB 20X12X140	1
22	1640501400	FRONT COVER	1	78	4026510552	SEEGER I102	1
23	1647001600	REAR OIL DISC	1	79	4026510558	SEEGER I120	4
24	1647002000	FRONT OIL DISC	1	80	4026701602	PLUG 3/8	3
25	165104E6B0	TIMING GEAR	1	81	4026701603	PLUG 1/2	5
26	165104E7B0	ADJUSTABLE TIMING GEAR	1	82	4026701604	PLUG 3/4	9
27	1662500900	BENCH	2	83	4026701622	MAGNETIC PLUG 3/4	2
28	1663063800	THERMOSTAT HOUSING	1	84	4026904510	PLUG M22X1.5	1
29	1680710500	GASKET	1	85	4026910008	VENTIL PLUG 3/4	4
30	1680710600	GASKET	2	86	4026910104	VENTIL PLUG 3/4 WITH VALVE	2
31	1680711700	GASKET	2	87	4026910602	PLUG G1/4	4
32	1680711800	GASKET	1	88	4027400415	CLAPET VALVE DN200 PN6	1
33	1680711900	GASKET PVT700	2	89	4028249B00	THERMOSTAT	1
	16807D1WB0	GASKET PVT1000	2				
34	1681008900	BEARING FLANGE	2		1892007400	GASKET KIT PVT700	1
35	1681009300	BEARING FLANGE	2		1892007500	GASKET KIT PVT1000 IL	1
36	1685002700	WASHER 35X13X6	8				
37	1685100200	WASHER 17X22X1.5 AL	1				
38	16851ABUB0	WASHER 28X22.5X1.5 CU	2				
39	1687509200	HOUSING PVT700	1				
	1687509900	HOUSING PVT1000	1				
40	4022104504	OIL SIGHT GLASS 3/4	4				
41	4022200152	Y-SEAL	1				
42	4022200305	OR 3256	1				
43	4022200327	OR 3275	2				
44	4022200328	OR 119	28				
45	4022200329	OR 3237	2				
46	4022202807	Y-SEAL	4				
47	4022203603	PTFE RING	8				
48	4023105014	BEARING 22213 E C3	2				
49	4023110096	BEARING NU314 ECJ C3	1				
50	4023110097	BEARING NU315 ECJ C3	2				
51	4026101301	SCREW M6X10	3				
52	4026101813	SCREW M20X50	4				
53	4026120506	SCREW M10X30	8				

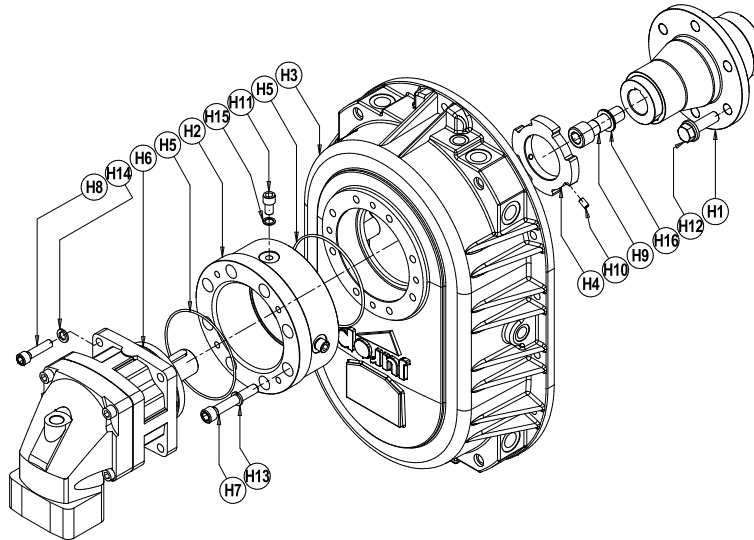
**PVT 700 - 1000 HDR**
**PVT 700 HDR**

Pos.	Codice	Descrizione	Q.tà	Pos.	Codice	Descrizione	Q.tà
H1	1611001600	PVT700 HDR JOINT	1	H9	4026121922	SCREW TCEI M22X70 GALV.	1
H2	1611001700	HDR MOTOR MOUNTING FLANGE	1	H10	4026135407	SCREW M8X14	2
H3	1640501700	PVT1000 HDR FRONT COVER	1	H11	4026186C00	SCREW TCEI M12X1X20	2
H4	1651011800	PVT700 HDR GEAR	1	H12	40261D3C10	SCREW TE FLANG M16X50	6
H5	4022200346	OR 4562 VITON	2	H13	4026350509	WASHER GROWER 14 GALV.	8
H6	4024107505	HDR MOTOR	1	H14	4026350709	WASHER GROWER 12 GALV.	4
H7	4026120718	SCREW TCEI M14X90 GALV.	8	H15	4026359006	WASHER 13,5X18X1,5	2
H8	4026121713	SCREW TCEI M12X50 GALV.	4	H16	4026385C33	WASHER M22	1

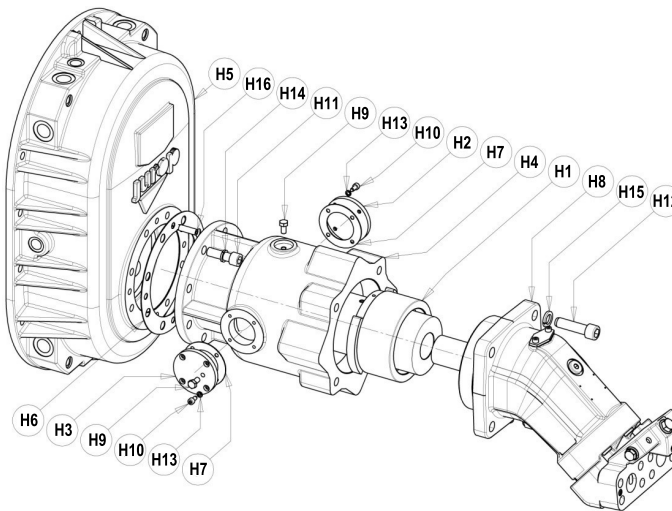
**PVT 1000 HDR**

**PVT 700 - 1000 HDR**

Pos.	Code	Description	Q.ty	Pos.	Code	Description	Q.ty
1	1470106300	JOINT	1	9	4026103402	SCREW M8X1X10	2
2	1610051700	FLANGE	1	10	4026120301	SCREW M6X12	8
3	1610051900	FLANGE FOR 2° REV. COUNTER	1	11	4026120712	SCREW M14X45	8
4	1612504600	HDR MOTOR MOUNTING FLANGE	1	12	4026121215	SCREW M16X60	4
5	1640501700	FRONT COVER HDR	1	13	4026350503	WASHER GROWER M6 SQUARE	5
6	1680701400	GASKET	1	14	4026350509	WASHER GROWER M14 SQUARE	8
7	1680709700	GASKET	2	15	4026350611	WASHER GROWER M16 FLAT	4
8	4024107765	HYDRAULIC MOTOR PVT1000	1	16	4026401806	PIN 10X36	4

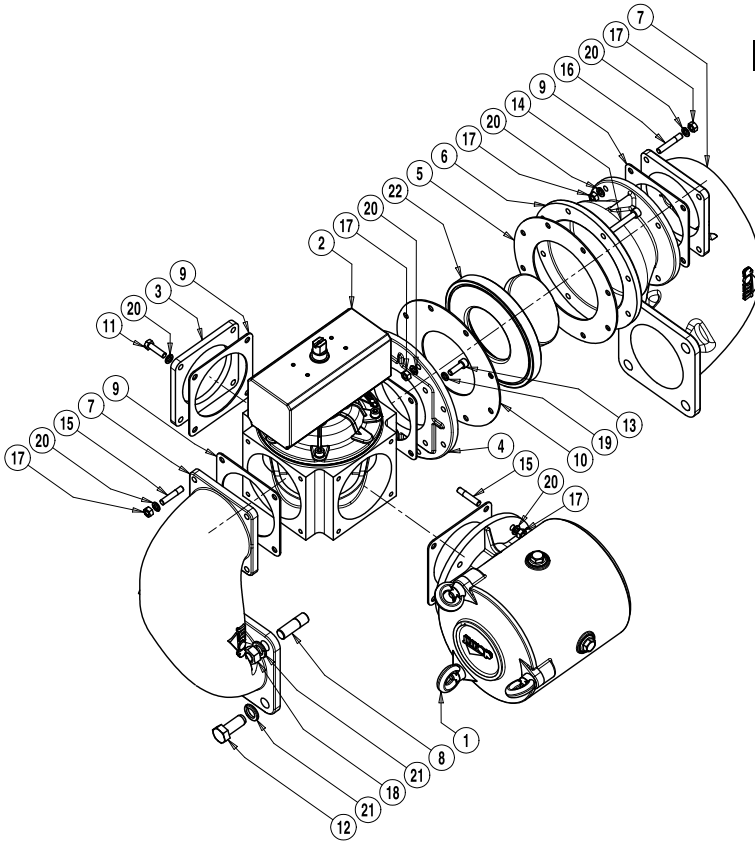

**SUCTION GROUP PVT**

**Suction group PVT200**



Pos.	Code	Description	Q.ty
1	1445002900	AIR FILTER	1
	14450MNZB0	ADR AIR FILTER	1
2	1488102900	4 WAYS VALVE	1
3	16100BDSB0	FLANGE	1
4	1610513800	FLANGE	1
5	1612088GB0	FLANGE	1
6	1627506500	CLAPET MANIFOLD	1
7	1627508200	SUCTION-EXHAUST MANIFOLD	2
8	1672001700	THREADED ROD M16X52	4
9	1680609100	GASKET	5
10	1680710300	GASKET	1
11	4026102808	SCREW M8X30	4
12	4026103210	SCREW M16X40	4
13	4026120405	SCREW M8X25	4
14	4026121412	SCREW M8X60	8
15	4026171603	THREADED ROD M8X30	8
16	4026171604	THREADED ROD M8X35	4
17	4026308005	BOLT M8	24
18	4026308009	BOLT M16	4
19	4026350505	WASHER GROWER M8 QUADRA	4
20	4026350706	WASHER GROWER M8 PIATTA	28
21	4026350711	WASHER GROWER M16 PIATTA	8
22	4027400413	CLAPET VALVE DN125 PN6	1

**Suction group PVT280**

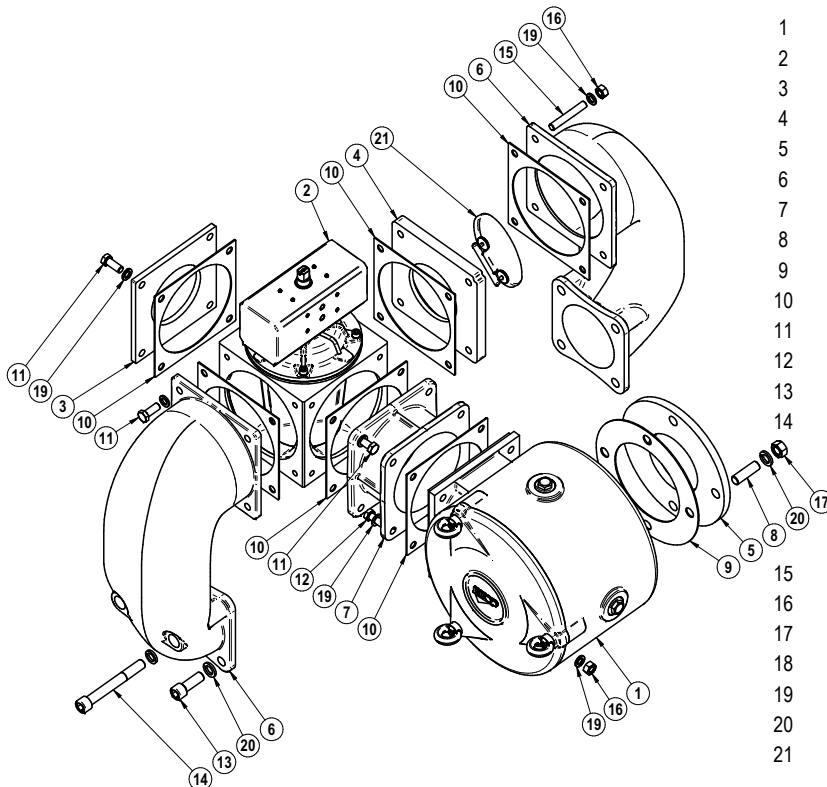

Pos.	Code	Description	Q.ty
1	1445003200	AIR FILTER	1
2	1488102200	4 WAYS VALVE	1
3	1612001300	FLANGE	1
4	16120107E0	PLATE FOR CLAPET VALVE DN150 PN10	1
5	1612011100	FILTER PR 200-250	1
6	16271002E0	SUCTION EXHAUST MANIFOLD	2
7	1627102100	MANIFOLD	1
8	1672001700	THREADED ROD M 16X52	4
9	1680609500	GASKET	1
10	1680609600	GASKET	6
11	4026103002	SCREW M12X30	12
12	4026103006	SCREW M12X50	4
13	4026121212	SCREW TCEI M16 X 45	4
14	4026121222	SCREW TCEI M 16 X 130	4
15	4026171207	THREADED ROD M 12 X 60	4
16	4026308007	BOLT M 12	8
17	4026308009	BOLT M 16	4
18	4026350510	WASHER GROWER 16 QUADRA	4
19	4026350709	WASHER GROWER 12 PIATTA	24
20	4026350711	WASHER GROWER 16 PIATTA	8
21	18930005E0	CLAPET VALVE DN150 PN10	1

Suction group PVT400

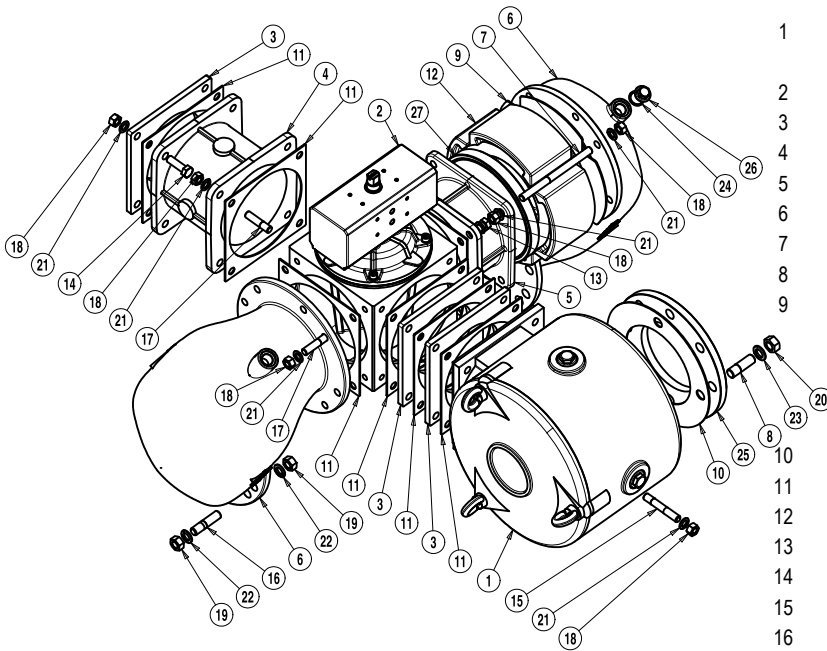

Pos.	Code	Description	Q.ty
1	1445003200	AIR FILTER	1
	14450GU6B0	ADR AIR FILTER	1
2	1488102200	4 WAYS VALVE	1
3	1612011500	FLANGE	3
4	1627101700	MANIFOLD L141	1
5	1627102100	MANIFOLD L87.5	1
6	1627507200	SUCTION-EXHAUST MANIFOLD	2
7	1671001300	THREADED ROD	4
8	1672001700	THREADED ROD M16X52	4
9	1680609400	GASKET	1
10	1680609500	GASKET	1
11	1680609600	GASKET	7
12	16871YAVA0	CLAPET VALVE MANIFOLD	1
13	4026103002	SCREW M12X30	4
14	4026103004	SCREW M12X40	4
15	4026171207	THREADED ROD M12X60	4
16	4026171304	SCREW M14X40	16
17	4026171704	SCREW M12X35	8
18	4026308007	BOLT M12	24
19	4026308008	BOLT M14	32
20	4026308009	BOLT M16	4
21	4026350709	WASHER GROWER M12 FLAT	28
22	4026350710	WASHER GROWER M14 FLAT	32
23	4026350711	WASHER GROWER M16 FLAT	4
24	4026359003	WASHER 21.5X26X1.5 AL	4
25	4026713008	FLANGE	1
26	4026904001	PLUG 1/2	2
27	4027400414	CLAPET VALVE DN150 PN6	1

Suction group PVT700

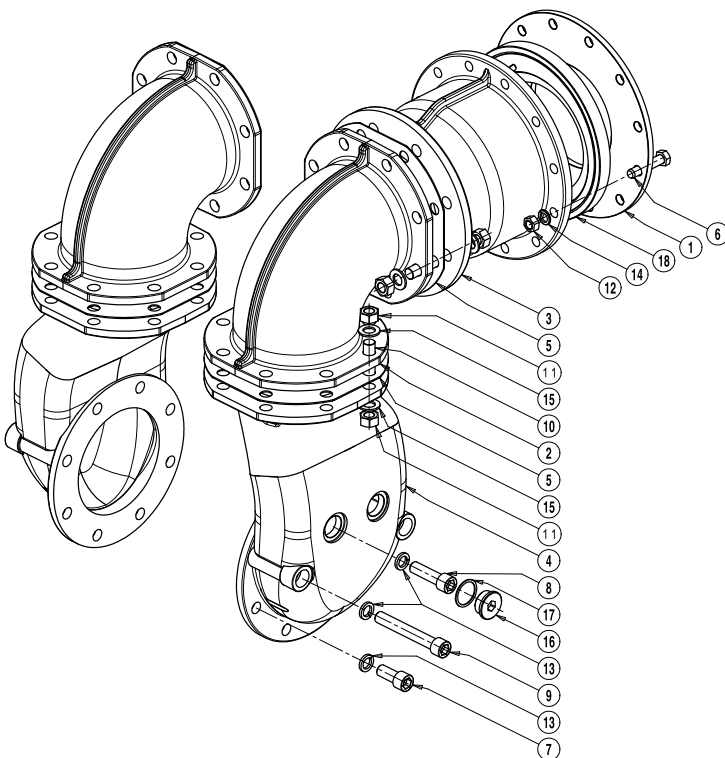

Pos.	Code	Description	Q.ty
1	16100KKDB0	FLANGE DN250 PN6	1
2	1627104900	90° MANIFOLD	2
3	1627105000	CLAPET MANIFOLD DN250	1
4	1627508000	MANIFOLD	2
5	1680711800	GASKET DN250 PN10	4
6	4026103217	SCREW M16X75	12
7	40261FPB13	SCREW M20X45	8
8	40261FPB17	SCREW M20X70	4
9	40261FPB24	SCREW M20X140	4
10	40261MYB00	THREADED ROD M20X73	24
11	4026308011	BOLT M20	48
12	4026308009	BOLT M16	12
13	4026350512	WASHER GROWER M20 SQUARE	16
14	4026350711	WASHER GROWER M16 FLAT	12
15	4026356111	WASHER M20	48
16	4026701606	PLUG 1 1/4	4
17	4026702707	COPPER WASHER 1 1/4	4
18	4027400416	CLAPET VALVE DN250	1

**Suction group PVT700**

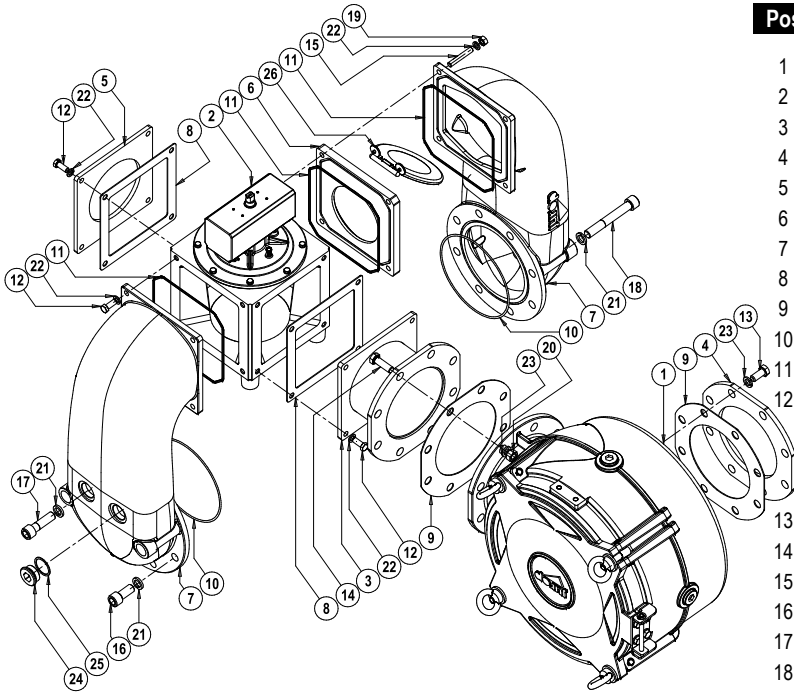

Pos.	Code	Description	Q.ty
1	1445006800	AIR FILTER D400	1
2	14881BWPB0	4 WAYS VALVE	1
3	15260033E0	MANIFOLD	1
4	16100083E0	FLANGE DN175	1
5	16100M4BB0	FLANGE 8"	1
6	16120660E0	CLAPET-PLATE DN200 PN10	1
7	16271013E0	MANIFOLD ASP/SC GA	2
8	1680605300	GASKET	2
9	1680711800	GASKET DN175 PN10	2
10	4022200309	ANELLO OR 4875 VITON	2
11	4022200375	ANELLO OR 41050 VITON	3
12	4026103002	SCREW TE M12X30 GALV.	12
13	4026103209	SCREW TE M16X35 GALV.	8
14	4026103212	SCREW TE M16X50 GALV.	8
15	4026171206	SCREW M12X55 GALV.	4
16	40261FPB13	SCREW TCEI M20X45 GALV.	8
17	40261FPB17	SCREW TCEI M20X70 GALV.	4
18	40261FPB24	SCREW TCEI M20X140 GALV.	4
19	4026308007	NUT M 12 ESAG. GALV.	4
20	4026308009	NUT M 16 ESAG. GALV.	8
21	4026350512	WASHER GROWER 20 GALV.	16
22	4026350709	WASHER GROWER 12 GALV.	16
23	4026350711	WASHER GROWER 16 GALV.	16
24	4026701606	PLUG 1"1/4 FE GALV.	4
25	4026702707	WASHER 1"1/4	4
26	4027400488	CLAPET DN200 PN10 INOX	1

**Flushing kit**

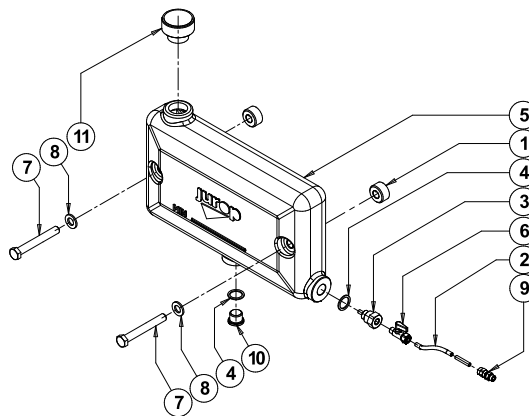

Pos.	Code	Description	Q.ty	Pos.	Code	Description	Q.ty
1	1624042800	SPACER	2	7	4026103013	SCREW TE M12X90 GALV.	2
2	16636009E0	PIPE RILSAN 4X6 L1500MM	1	8	4026357007	WASHER M12 GALV.	2
3	1673001000	FILTER LINK	1	9	4026702004	CONNECTION DIR 6X1/8	1
4	1685100300	WASHER DI 20	2	10	4026904503	PLUG M20X1,5	1
5	1687600000	SIDE OIL TANK	1	11	4026910103	PLASTIC VENT 1"	1
6	4024405400	VALVE G1/8	1				

<b>Model</b>	<b>Issue date</b>	<b>Revision No.</b>	<b>Revision date</b>	<b>Filled out by</b>	<b>Viewed by</b>
PVT SERIES	03-11-2010	13	03-08-2018	U.T.	A.T.

## **Juop SpA**

Via Crosera, 50  
33082 Azzano Decimo, PN (ITALY)

Tel. +39 0434 636811  
Fax. +39 0434 636812

<http://www.juop.it>  
e-mail: [info@juop.it](mailto:info@juop.it)

Juop SpA reserves the right to modify the products described in this manual without prior notice.